

**OLYMPUS**

DIGITAL CAMERA

**FE-210/X-775**

# Basic Manual

ENGLISH 2

FRANÇAIS 28

ESPAÑOL 54

PORTUGUÊS 80

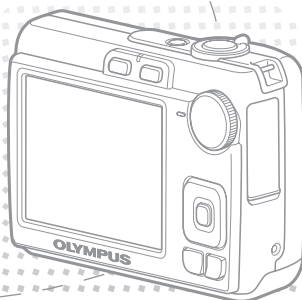
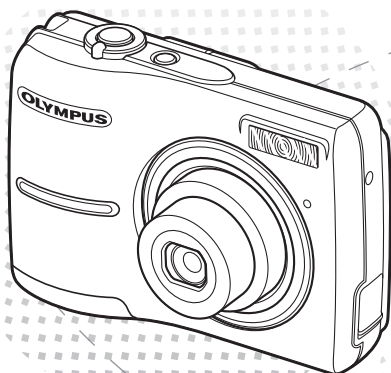

# Table of Contents

<b>Gather these items (box contents)</b> .....	<b>3</b>
<b>Insert the batteries</b> .....	<b>4</b>
<b>Turn the camera on</b> .....	<b>5</b>
<b>Set date and time</b> .....	<b>6</b>
<b>Select a Language</b> .....	<b>8</b>
<b>Take a picture</b> .....	<b>9</b>
<b>Review your pictures</b> .....	<b>10</b>
<b>Basic Operation</b> .....	<b>11</b>
Shooting Mode Buttons.....	11
Mode dial.....	12
<b>SCENE</b> Modes.....	12
Macro Mode.....	13
Flash Modes.....	13
Self-Timer.....	14
Power Save Feature.....	14
<b>Menus and Settings</b> .....	<b>15</b>
Top Menu.....	15
Erase All Pictures.....	15
<b>Connecting the Camera</b> .....	<b>16</b>
Playback on a TV.....	16
Direct Printing (PictBridge).....	17
<b>Transfer Images</b> .....	<b>18</b>
<b>OLYMPUS Master Software</b> .....	<b>20</b>
<b>Specifications</b> .....	<b>21</b>
<b>Safety Precautions</b> .....	<b>22</b>
● Before using your camera, read this manual carefully to ensure correct use.	
● We recommend that you take test shots to get accustomed to your camera before taking important photographs.	
● Please observe the safety precautions at the end of this manual.	
● The images of the LCD screen and illustrations of the camera used in this manual may differ from the actual product.	

# Gather these items (box contents)



Digital camera



Strap



AA batteries  
(2)

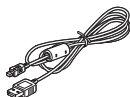

USB cable

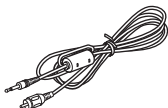

Video cable



OLYMPUS Master CD-ROM

En

## Other items

- Basic Manual (this manual)
  - Advanced Manual
  - Warranty card
- Contents may vary depending on purchase location.

## Attach the strap

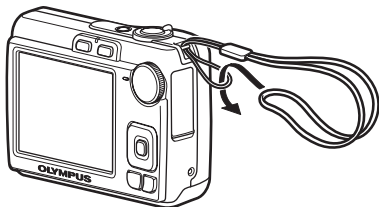

- Pull the strap tight so that it does not come loose.

# Insert the batteries

a. Insert the batteries into the camera.

En

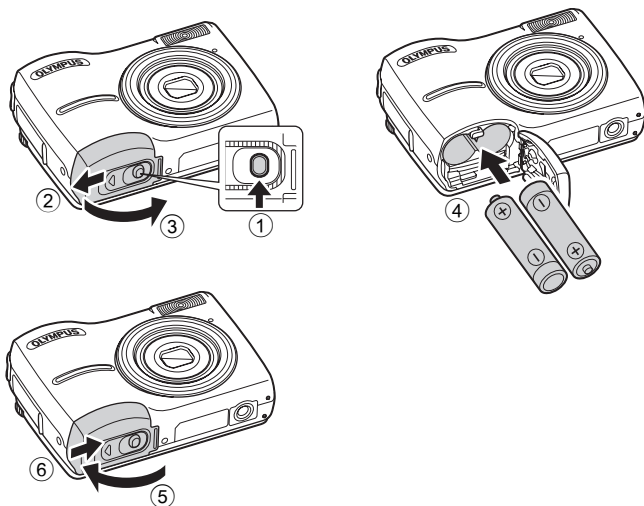

- Even when an optional xD-Picture Card™ (hereinafter called the card) is not inserted, you can take a picture. For details on inserting an optional card, please refer to Advanced Manual.

## Hint

The directions of the arrow pad ( $\triangle \nabla \langle \rangle$ ) is indicated with  $\triangle \nabla \langle \rangle$  in this manual.

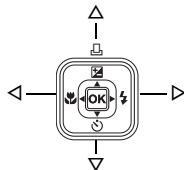

# Turn the camera on

This explains how to turn on the camera in shooting mode.

## a. Set the mode dial to **AUTO**.

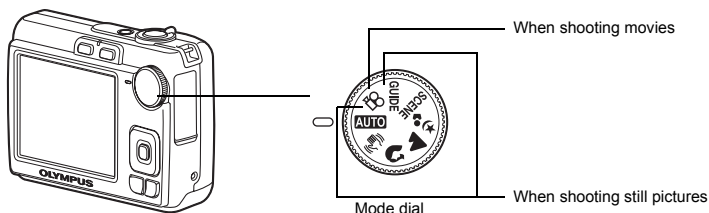

En

## Still picture shooting modes

<b>AUTO</b>	This function allows you to shoot with the camera's automatic settings.
	This function stabilizes images when taking pictures.
	Suitable for taking pictures of people.
	Suitable for taking pictures of landscapes.
	Suitable for taking pictures of people at night.
<b>SCENE</b>	Select from 10 scene modes according to the shooting conditions.
<b>GUIDE</b>	Use the shooting guide displayed on the screen to shoot pictures according to the situation.

## b. Press the **POWER** button.

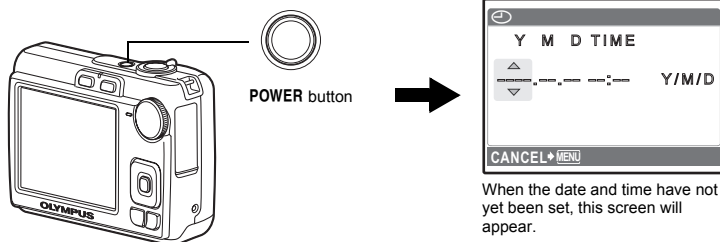

When the date and time have not yet been set, this screen will appear.

- To turn off the camera, press the **POWER** button once again.

# Set date and time

## About the date and time setting screen

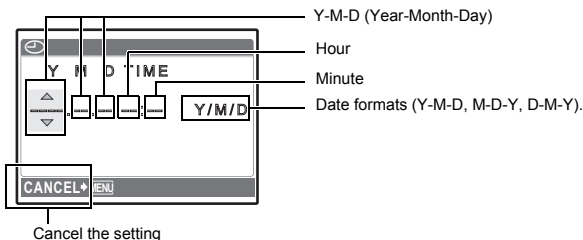

En

- a. Press the  $\Delta$  / button and the  $\nabla$  button to select [Y].

● The first two digits of [Y] are fixed.

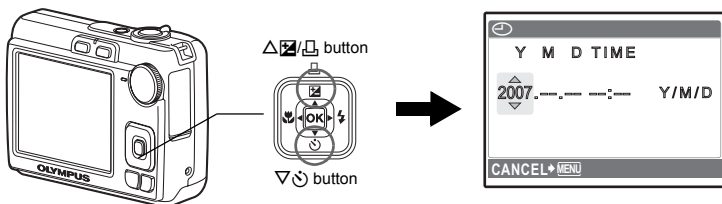

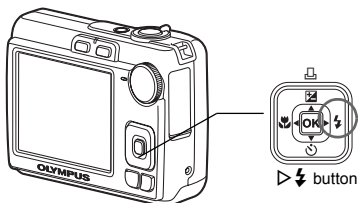

- b. Press the  $\triangleright$  button.

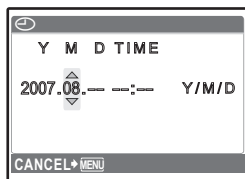

- c. Press the  $\Delta$  / button and the  $\nabla$  button to select [M].



- d. Press the  $\triangleright$  button.

e. Press the  button and the  button to select [D].

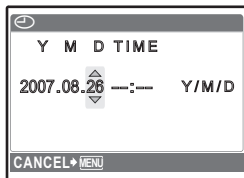

f. Press the  button.

g. Press the  button and the  button to select “hour” and “minute”.

- The time is displayed in the 24-hour format.

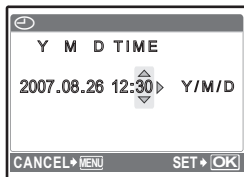

h. Press the  button.

i. Press the  button and the  button to select [Y/M/D].

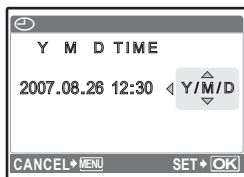

j. After all items have been set, press the  button.

- For a more accurate setting, you can press the  button when the time signal hits 00 seconds.

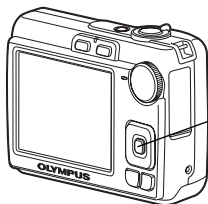

En

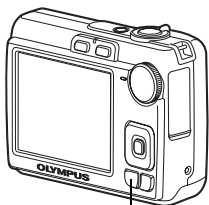

# Select a Language

- a. Press the MENU button to display the Top Menu.

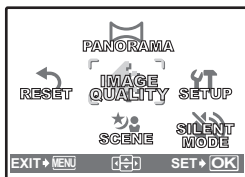

MENU button



- b. Press the  button to select [SETUP], and press the  button.

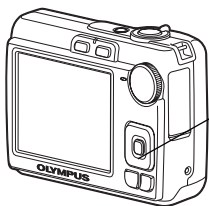



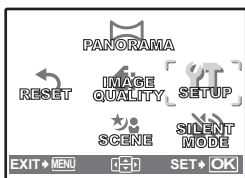

 button

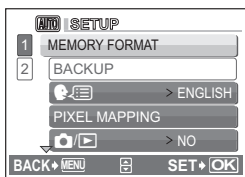

- c. Press the  button and the  button to select , and press the  button.



- d. Use arrow pad (   ) to select a language, and press the  button.

- You can add other languages to your camera with the provided OLYMPUS Master software. Please refer to the Advanced Manual.

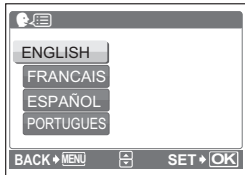



# Take a picture

## a. Hold the camera.

Horizontal grip

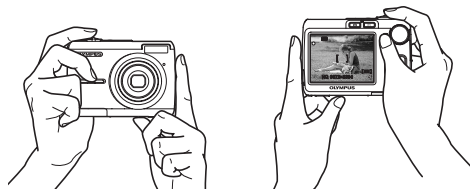

Vertical grip

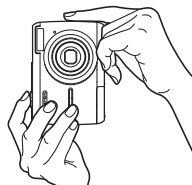

En

## b. Focus.

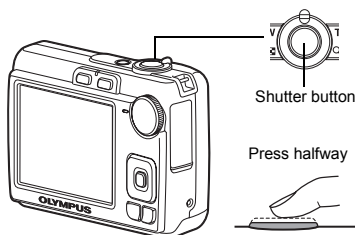

Shutter button

Press halfway

Place this mark over your subject.



The number of remaining still pictures you can store is displayed.

The green lamp indicates the focus and exposure are locked.

## c. Shoot.

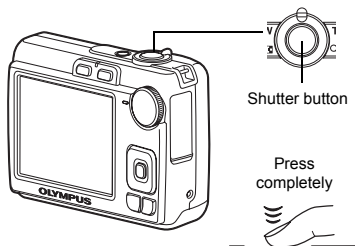

Shutter button

Press completely

The card access lamp blinks.



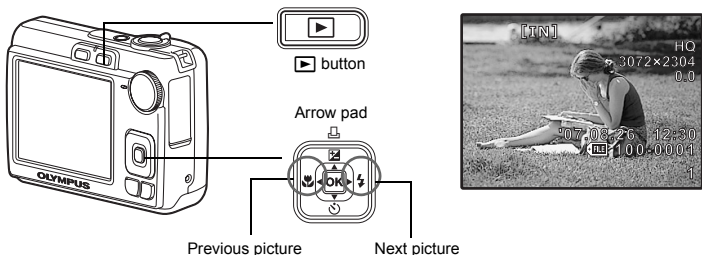

# Review your pictures

- a. Press the  button.



En

## Erase pictures

- a. Press the  button and the  button to display the picture you want to erase.
- b. Press the  button.

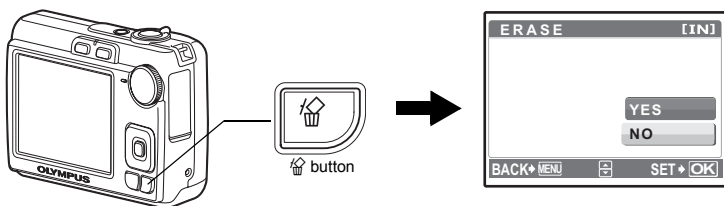

- c. Press the  button to select [YES], and press the  button.

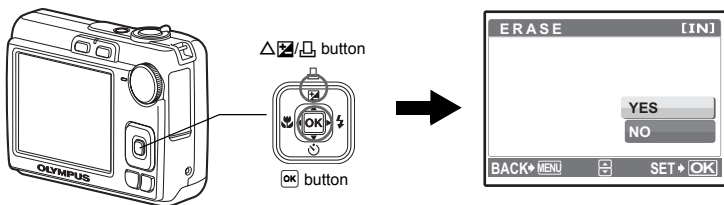

# Basic Operation

## Shooting Mode Buttons

While in shooting mode, use these buttons for quick access to some of the more commonly used features.

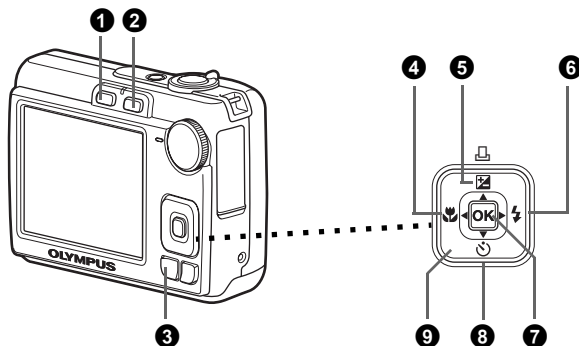

En

- 1** **button (Shooting)**  
Selects the shooting mode.
- 2** **button (Playback)**  
Selects the playback mode.
- 3** **MENU button**  
Press this button to display the Top Menu.
- 4** **button (Macro Mode)**  
Use macro or super macro mode when taking close-up pictures such as of a flower.
- 5** **button (Exposure Compensation/Print)**  
Press this button in shooting mode to adjust to overexpose (+) or underexpose (-) a picture.
- 6** **button (Flash Mode)**  
Select from 4 flash modes - FLASH AUTO, REDEYE, FILL IN, or FLASH OFF.
- 7** **button**  
Press to confirm settings.
- 8** **button (Self-timer)**  
Select the self-timer to delay the shot approximately 12 seconds from when the shutter button is pressed.
- 9** **Arrow pad ( )**  
Selects scenes, playback pictures and menu items.

## Mode dial

Set the desired mode and turn the camera on. You may select the desired mode before or during use.

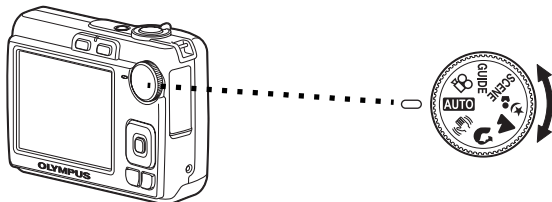

En

<b>AUTO</b>	This function allows you to shoot with the camera's automatic settings.
	This function stabilizes images when taking pictures.
	Suitable for taking pictures of people.
	Suitable for taking pictures of landscapes.
	Suitable for taking pictures of people at night.
<b>SCENE</b>	Select from 10 scene modes according to the shooting conditions.
	This function lets you record movies.
<b>GUIDE</b>	Use the shooting guide displayed on the screen to shoot pictures according to the situation.

## SCENE Modes

Select the shooting mode depending on an object.

- 1 Set the mode dial to **SCENE**, and select the other scene.

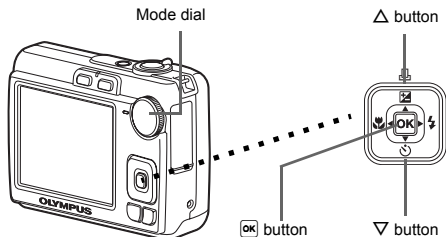
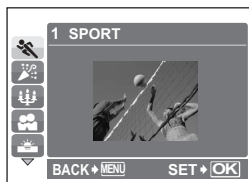









- 2 Press  $\Delta/\nabla$  to select the scene modes and press **OK**.

## Shooting SCENE Modes





-  SPORT
-  INDOOR
-  CANDLE
-  SELF PORTRAIT
-  SUNSET
-  FIREWORKS
-  BEHIND GLASS
-  CUISINE
-  DOCUMENTS
-  AUCTION



### Macro Mode

-  This mode lets you take pictures as close as 10 cm (3.9 in.) to your subject. (Most wide-angle side)
  -  Use this mode to take pictures as close as 5 cm (2.0 in.) to your subject. In  mode, the position of the zoom lens is fixed.
- 1 Press   repeatedly to select [] or [] and press .



En

### Flash Modes

- 1 Press   repeatedly to select the flash mode and press .
- 2 Press the shutter button halfway.
  - When the flash is set to fire, the  mark lights.
- 3 Press the shutter button completely to take the picture.

Icon	Flash Mode	Description
<b>AUTO</b>	FLASH AUTO	The flash fires automatically in low light or backlight conditions.
	REDEYE	This emits pre-flashes to reduce the occurrence of red-eye in your pictures.
	FILL IN	The flash fires regardless of the available light.
	FLASH OFF	The flash does not fire even in low light conditions.

## Self-Timer

- 1 Press  $\nabla$   to select [] and press .
- 2 Press the shutter button completely to take the picture.
  - The self-timer lamp lights for approximately 10 seconds after the shutter button is pressed, then starts blinking. After blinking for approximately 2 seconds, the picture is taken.

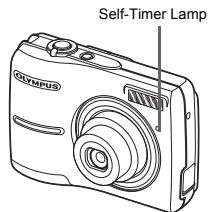

En

## Power Save Feature

- To save battery power, the camera automatically enters sleep mode and stops operating if not used for approximately 3 minutes. Press the shutter button or zoom lever to reactivate the camera.
- If the camera is not operated for 12 minutes after the camera enters sleep mode, it automatically retracts the lens and turns off. To resume operation, turn on the power again.

# Menus and Settings

## Top Menu

- 1 Press **MENU** to display the Top Menu.

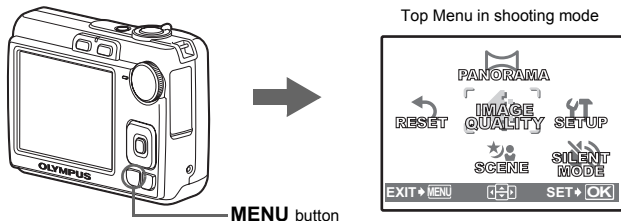

En

- 2 Use the arrow pad ( $\Delta/\nabla/\triangleleft/\triangleright$ ) to select menu items, and press **OK** to set them.

### PANORAMA

Panorama shooting lets you create a panoramic picture, using the OLYMPUS Master software from the provided CD-ROM. An Olympus xD-Picture Card is required for panorama shooting.

### RESET

Return the changed shooting functions back to default settings.

### IMAGE QUALITY

Set the image quality of the picture you will shoot according to its intended purpose.

### SETUP

Set the date, time, language, and operation sound, etc.

### SCENE (Scene mode)

Select the scene mode according to the subject and shooting and condition when the **SCENE** mode is selected.

### SILENT MODE

Mute operational sounds that occur during shooting and playback.

## Erase All Pictures

- 1 Press **MENU** in playback mode to display the Top Menu and select **[ERASE] > [ALL ERASE]**.
- 2 Select **[YES]**, and press **OK**.
  - All the pictures are erased.

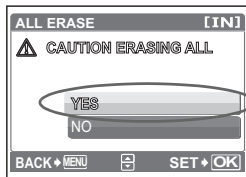





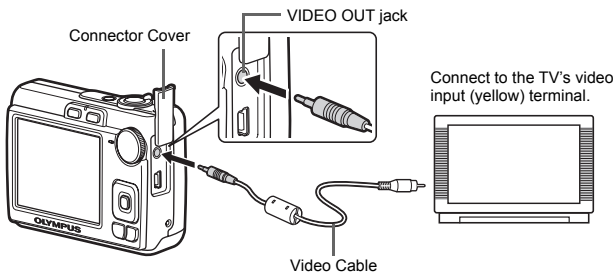

# Connecting the Camera

## Playback on a TV

Use the video cable provided with the camera to playback recorded images on your TV. Both still pictures and movies can be played back.

- 1 Make sure that the TV and camera are turned off. Connect the VIDEO OUT jack on the camera to the video input terminal on the TV using the video cable.



- 2 Turn the TV on and set it to the video input mode.
  - For details of switching to video input, refer to your TV's instruction manual.
- 3 Turn on the camera and then press  to enter playback mode.
  - The last picture taken is displayed on the TV. Use the arrow pad (, , , ) to select the picture you want to display.

En



## Direct Printing (PictBridge)

Using the provided USB cable, you may connect your camera directly to a PictBridge compatible printer to make prints. You can print a picture with simple operations.

- 1 In playback mode, display the picture you want to print out on the monitor.
- 2 Connect one end of the provided USB cable into the camera's USB connector and the other end into the printer's USB connector.

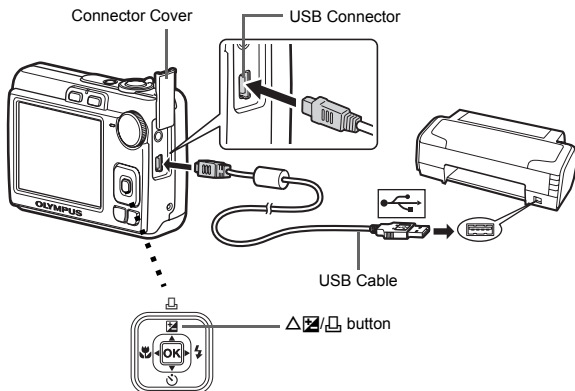

En

- 3 Press  $\triangle$  .
  - Printing starts.
  - When printings finished, disconnect the USB cable from the camera with the picture selection screen displayed.

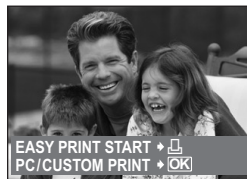

# Transfer Images

## Install the software

- 1 Insert the OLYMPUS Master CD-ROM.
- 2 **Windows:** Click the "OLYMPUS Master 2" button.  
**Macintosh:** Double-click the "Setup" icon.
- 3 Simply follow the on-screen instructions.

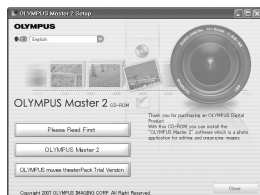

En

## Connect the camera to the computer

- 1 Connect the camera and computer using the USB cable (included).
  - The monitor will turn on automatically.

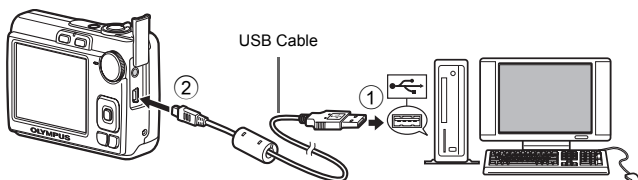

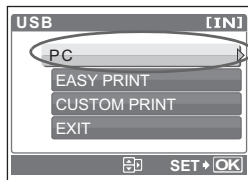

- 2 Select [PC] on the monitor, and press **OK**.



- Your PC will now recognize your camera as a removable storage drive.

## Transfer images to the computer

- 1 With the camera now connected, open OLYMPUS Master.
- 2 Click “Transfer Images”  on the browse window, and then click “From Camera”  .
- 3 Simply follow the on-screen instructions.

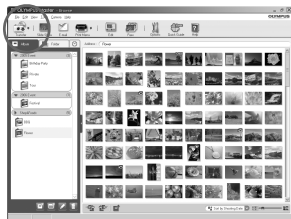

En

### Tips

- For more detailed information regarding camera setup and usage, please refer to the camera’s “Advanced Manual” provided on CD-ROM.
- For additional assistance, refer to the “Help” file in the OLYMPUS Master software.

# OLYMPUS Master Software

OLYMPUS Master Software: Use this software to download pictures from the camera, view, organize, retouch, e-mail and print your digital pictures and movies and more!



## ● System Requirements

En

OS	Windows 2000 Professional/XP Home Edition/XP Professional/Vista or Mac OS X (10.3 or later)
CPU	Pentium III 500 MHz/Power PC G3 500 MHz/Intel Core Solo/Duo 1.5GHz or faster
RAM	256 MB or more
Hard Disk	500 MB or more free space
Connection	USB port/IEEE 1394 port (FireWire)
Monitor	1024 × 768 pixels resolution or more with minimum 65,536 colors (Windows), 32,000 colors (Macintosh)
Other	Internet Explorer 6 or later (Windows) Safari 1.0 or later, QuickTime 6 or later (Macintosh)

For the latest support information, visit the Olympus website (<http://www.olympus.com/digital>)



### User Registration

Register your camera when you install OLYMPUS Master to activate your warranty, receive notifications of software and camera firmware updates, and more.

# Specifications

## ● Camera

Product type	: Digital camera (for shooting and displaying)
Recording system	
Still pictures	: Digital recording, JPEG (in accordance with Design rule for Camera File system (DCF))
Applicable standards	: Exif 2.2, Digital Print Order Format (DPOF), PRINT Image Matching III, PictBridge
Movie	: AVI Motion JPEG
Memory	: Internal memory xD-Picture Card (16 MB to 2 GB) (Type H/M, Standard)
Number of effective pixels	: 7,100,000 pixels
Image pickup device	: 1/2.5" CCD (primary color filter), 7,400,000 pixels (gross)
Lens	: Olympus lens 6.3 to 18.9 mm, f3.1 to 5.9 (equivalent to 38 to 114 mm on a 35 mm camera)
Photometric system	: Center-weighted metering
Shutter speed	: 4 to 1/2000 sec.
Shooting range	: 0.6 m (2.0 ft.) to ∞ (W), 1.0 m (3.3 ft.) to ∞ (T) (normal) 0.1 m (0.3 ft.) to ∞ (W), 0.6 m (2.0 ft.) to ∞ (T) (macro mode) 0.05 m (2.0 in.) to ∞ (super macro mode)
Monitor	: 2.5" TFT color LCD display, 154,000 pixels
Outer connector	: DC-IN jack, USB connector, VIDEO OUT jack
Automatic calendar system	: 2000 up to 2099
Operating environment	
Temperature	: 0°C to 40°C (32°F to 104°F) (operation)/ -20°C to 60°C (-4°F to 140°F) (storage)
Humidity	: 30% to 90% (operation)/10% to 90% (storage)
Power supply	: AA batteries 2 each (Oxyride batteries/Alkaline battery/ NiMH battery) or specified AC adapter
Dimensions	: 90 mm (W) × 62.5 mm (H) × 30.5 mm (D) (3.5 × 2.5 × 1.2 in.) (excluding protrusions)
Weight	: 122 g (4.3 oz) (without battery and card)

Please note that design and specification improvements may result in unannounced changes.

# Safety Precautions



## CAUTION

RISK OF ELECTRIC SHOCK  
DO NOT OPEN



**CAUTION:** TO REDUCE THE RISK OF ELECTRICAL SHOCK, DO NOT REMOVE COVER (OR BACK). NO USER-SERVICEABLE PARTS INSIDE. REFER SERVICING TO QUALIFIED OLYMPUS SERVICE PERSONNEL.



An exclamation mark enclosed in a triangle alerts you to important operating and maintenance instructions in the documentation provided with the product.



### DANGER

If the product is used without observing the information given under this symbol, serious injury or death may result.



### WARNING

If the product is used without observing the information given under this symbol, injury or death may result.



### CAUTION

If the product is used without observing the information given under this symbol, minor personal injury, damage to the equipment, or loss of valuable data may result.

#### WARNING!

TO AVOID THE RISK OF FIRE OR ELECTRICAL SHOCK, NEVER DISASSEMBLE, EXPOSE THIS PRODUCT TO WATER OR OPERATE IN A HIGH HUMIDITY ENVIRONMENT.

En

## General Precautions

**Read All Instructions** — Before you use the product, read all operating instructions. Save all manuals and documentation for future reference.

**Cleaning** — Always unplug this product from the wall outlet before cleaning. Use only a damp cloth for cleaning. Never use any type of liquid or aerosol cleaner, or any type of organic solvent to clean this product.

**Attachments** — For your safety, and to avoid damaging the product, use only accessories recommended by Olympus.

**Water and Moisture** — For precautions on products with weatherproof designs, read the weatherproofing sections.

**Location** — To avoid damage to the product, mount the product securely on a stable tripod, stand, or bracket.

**Power Source** — Connect this product only to the power source described on the product label.

**Lightning** — If a lightning storm occurs while using an AC adapter, remove it from the wall outlet immediately.

**Foreign Objects** — To avoid personal injury, never insert a metal object into the product.

**Heat** — Never use or store this product near any heat source such as a radiator, heat register, stove, or any type of equipment or appliance that generates heat, including stereo amplifiers.

## Handling the Camera



### WARNING

- **Do not use the camera near flammable or explosive gases.**
- **Do not use the flash on people (infants, small children, etc.) at close range.**
  - You must be at least 1 m (3 ft.) away from the faces of your subjects. Firing the flash too close to the subject's eyes could cause a momentary loss of vision.
- **Keep young children and infants away from the camera.**
  - Always use and store the camera out of the reach of young children and infants to prevent the following dangerous situations which could cause serious injury:
    - Becoming entangled in the camera strap, causing strangulation.
    - Accidentally swallowing the battery, cards or other small parts.
    - Accidentally firing the flash into their own eyes or those of another child.
    - Accidentally being injured by the moving parts of the camera.
- **Do not look at the sun or strong lights with the camera.**
- **Do not use or store the camera in dusty or humid places.**
- **Do not cover the flash with a hand while firing.**

En



### CAUTION

- **Stop using the camera immediately if you notice any unusual odors, noise, or smoke around it.**
  - Never remove the batteries with bare hands, which may cause a fire or burn your hands.
- **Never hold or operate the camera with wet hands.**
- **Do not leave the camera in places where it may be subject to extremely high temperatures.**
  - Doing so may cause parts to deteriorate and, in some circumstances, cause the camera to catch fire. Do not use the charger or AC adapter if it is covered (such as a blanket). This could cause overheating, resulting in fire.
- **Handle the camera with care to avoid getting a low-temperature burn.**
  - When the camera contains metal parts, overheating can result in a low-temperature burn. Pay attention to the following:
    - When used for a long period, the camera will get hot. If you hold on to the camera in this state, a low-temperature burn may be caused.
    - In places subject to extremely cold temperatures, the temperature of the camera's body may be lower than the environmental temperature. If possible, wear gloves when handling the camera in cold temperatures.
- **Be careful with the strap.**
  - Be careful with the strap when you carry the camera. It could easily catch on stray objects - and cause serious damage.

## Battery Handling Precautions

**Follow these important guidelines to prevent batteries from leaking, overheating, burning, exploding, or causing electrical shocks or burns.**



### **DANGER**

- Use only the Olympus brand NiMH batteries and fitting charger.
- Never heat or incinerate batteries.
- Take precautions when carrying or storing batteries to prevent them from coming into contact with any metal objects such as jewelry, pins, fasteners, etc.
- Never store batteries where they will be exposed to direct sunlight, or subjected to high temperatures in a hot vehicle, near a heat source, etc.
- To prevent causing battery leaks or damaging their terminals, carefully follow all instructions regarding the use of batteries. Never attempt to disassemble a battery or modify it in any way, by soldering, etc.
- If battery fluid gets into your eyes, flush your eyes immediately with clear, cold running water and seek medical attention immediately.
- Always store batteries out of the reach of small children. If a child accidentally swallows a battery, seek medical attention immediately.



### **WARNING**

- Keep batteries dry at all times.
- To prevent batteries from leaking, overheating, or causing a fire or explosion, use only batteries recommended for use with this product.
- Never mix batteries (old and new batteries, charged and uncharged batteries, batteries of different manufacture or capacity, etc.).
- Do not charge alkaline or lithium batteries if they are not rechargeable.
- Insert the battery carefully as described in the operating instructions.
- Do not use batteries if their body is not covered by the insulating sheet or if the sheet is torn, as this may cause fluid leaks, fire, or injury.



## CAUTION

- Do not remove batteries immediately after using the camera. Batteries may become hot during prolonged use.
- Always unload the battery from the camera before storing the camera for a long period.

- The following AA batteries cannot be used.

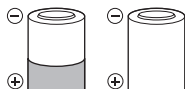

Batteries whose bodies are only partially or not at all covered by an insulating sheet.



Batteries whose  $\ominus$  terminals are raised, but not covered by an insulating sheet.

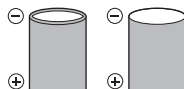

Batteries whose terminals are flat and not completely covered by an insulating sheet. (Such batteries cannot be used even if the  $\ominus$  terminals are partially covered.)

- If NiMH batteries are not charged within the specified time, stop charging them and do not use them.
- Do not use a battery if it is cracked or broken.
- If a battery leaks, becomes discolored or deformed, or becomes abnormal in any other way during operation, stop using the camera.
- If a battery leaks fluid onto your clothing or skin, remove the clothing and flush the affected area with clean, running cold water immediately. If the fluid burns your skin, seek medical attention immediately.
- Never subject batteries to strong shocks or continuous vibration.

## For customers in North and South America

### For customers in USA

Declaration of Conformity

Model Number : FE-210/X-775

Trade Name : OLYMPUS

Responsible Party : OLYMPUS IMAGING AMERICA INC.

Address : 3500 Corporate Parkway, P.O. Box 610, Center Valley,  
PA 18034-0610, U.S.A.

Telephone Number: 484-896-5000

Tested To Comply With FCC Standards

FOR HOME OR OFFICE USE

This device complies with Part 15 of the FCC rules. Operation is subject to the following two conditions:

- (1) This device may not cause harmful interference.
- (2) This device must accept any interference received, including interference that may cause undesired operation.

### For customers in Canada

This Class B digital apparatus meets all requirements of the Canadian Interference-Causing Equipment Regulations.

En

## Trademarks

- IBM is a registered trademark of International Business Machines Corporation.
- Microsoft and Windows are registered trademarks of Microsoft Corporation.
- Macintosh is a trademark of Apple Computer Inc.
- xD-Picture Card™ is a trademark.
- All other company and product names are registered trademarks and/or trademarks of their respective owners.
- The standards for camera file systems referred to in this manual are the "Design Rule for Camera File System/DCF" standards stipulated by the Japan Electronics and Information Technology Industries Association (JEITA).

---

## Memo

# Table des matières

Réunissez ces éléments (contenu de la boîte) .....	29
Insérez les batteries.....	30
Allumez l'appareil photo .....	31
Régler la date et l'heure .....	32
Sélection d'une langue.....	34
Prenez des photos .....	35
Vérifier les images .....	36
<b>Fonctionnement de base.....</b>	<b>37</b>
Touches du mode prise de vue .....	37
Molette mode.....	38
Modes <b>SCENE</b> (Scène).....	38
Mode gros plan .....	39
Modes flash .....	39
Retardateur.....	40
Fonctionnalité d'économie d'énergie .....	40
<b>Menus et réglages.....</b>	<b>41</b>
Menu principal .....	41
Effacement de toutes les photos .....	41
<b>Connexion de l'appareil photo .....</b>	<b>42</b>
Affichage sur un téléviseur .....	42
Impression directe (PictBridge).....	43
<b>Transfert d'images.....</b>	<b>44</b>
<b>Logiciel OLYMPUS Master .....</b>	<b>46</b>
<b>Caractéristiques.....</b>	<b>47</b>
<b>Précautions de sécurité .....</b>	<b>48</b>
● Avant d'utiliser votre appareil photo et pour garantir une utilisation correcte, lisez attentivement ce manuel.	
● Nous vous recommandons de prendre des photos-test pour vous habituer à votre appareil avant de commencer à prendre de vraies photos.	
● Veillez à ce que les mesures de sécurité présentées à la fin de ce manuel soient respectées.	
● Les captures de l'écran ACL et les illustrations de l'appareil photo utilisées dans ce manuel peuvent être différentes du produit réel.	

# Réunissez ces éléments (contenu de la boîte)



Appareil photo numérique



Courroie



Batteries AA (2)

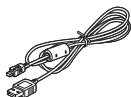

Câble USB

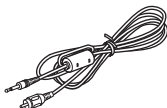

Câble vidéo



CD-ROM OLYMPUS Master

Fr

## Autres éléments

- Manuel de Base (ce manuel)
  - Manuel Avancé
  - Carte de garantie
- Le contenu est susceptible de varier en fonction du lieu d'achat.

## Attachez la courroie

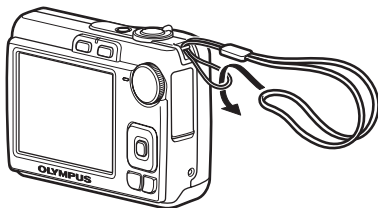

- Tendez la courroie afin qu'elle ne soit pas relâchée.

# Insérez les batteries

a. Insérez les batteries dans l'appareil photo.

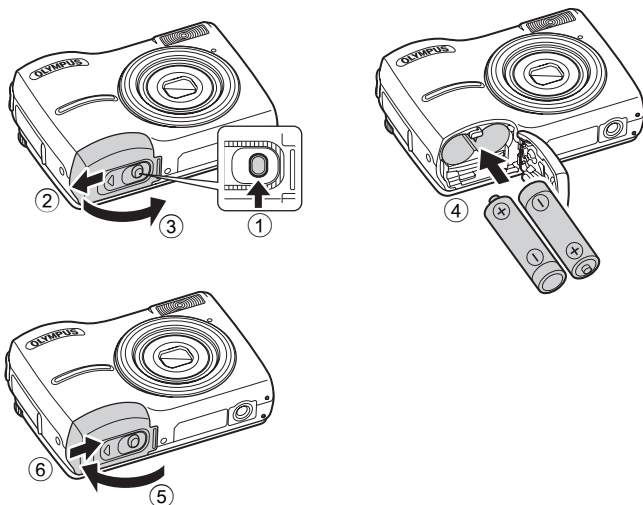

Fr

- Vous pouvez prendre une photo même si une carte xD-Picture Card™ optionnelle (appelée ci-après la carte) n'est pas insérée. Pour des informations concernant une carte optionnelle, veuillez vous reporter au Manuel Avancé.

## Conseil

Les directions de la molette de défilement ( $\Delta \nabla \langle \rangle$ ) sont indiquées par les symboles  $\Delta \nabla \langle \rangle$  dans le présent manuel.

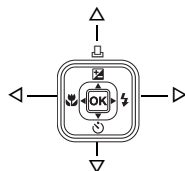



# Régler la date et l'heure

A propos de l'écran de réglage de la date et de l'heure

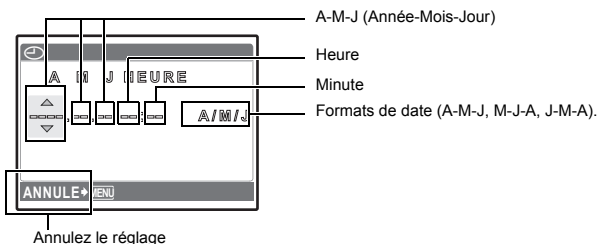

Fr

a. Appuyez sur la touche et la touche pour sélectionner [A].

● Les deux premiers chiffres de [A] sont fixes.

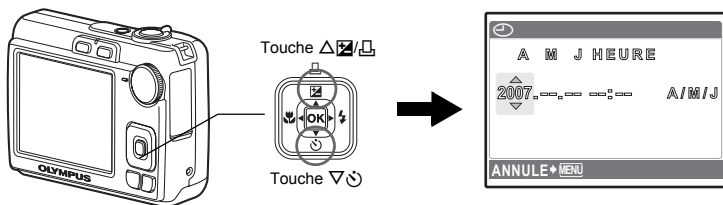



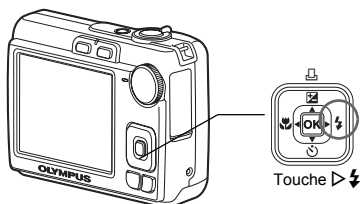

b. Appuyez sur la touche .

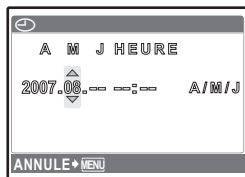





c. Appuyez sur la touche et sur la touche pour sélectionner [M].





- d. Appuyez sur la touche .
- e. Appuyez sur la touche / et sur la touche  pour sélectionner [J].







- f. Appuyez sur la touche .
- g. Appuyez sur la touche / et la touche  pour sélectionner "heure" et "minute".

- L'heure est affichée au format 24 heures.



Fr

- h. Appuyez sur la touche .
- i. Appuyez sur la touche / et sur la touche  pour sélectionner [A/M/J].



- j. Une fois que vous avez paramétré tous ces réglages, appuyez sur la touche .

- Pour un réglage plus précis, appuyez sur la touche  lorsque l'horloge franchit 00 seconde.

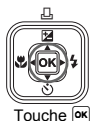
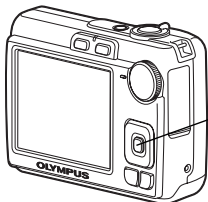



# Sélection d'une langue

- a. Appuyez sur la touche MENU pour afficher le menu principal.

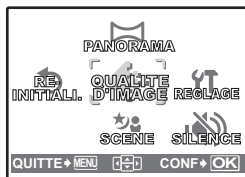

Touche MENU





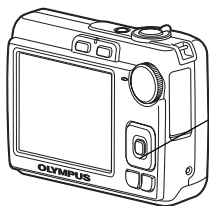



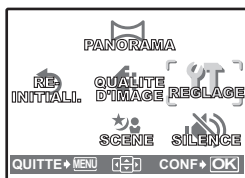

- b. Appuyez sur la touche  pour sélectionner [REGLAGE], puis appuyez sur la touche .



Touche 



- c. Appuyez sur la touche  et sur la touche  pour sélectionner , puis appuyez sur la touche .

- d. Utilisez la molette de défilement (, , , ) pour sélectionner une langue, puis appuyez sur la touche .

- Vous pouvez ajouter d'autres langues à l'appareil photo à l'aide du logiciel OLYMPUS Master fourni. Veuillez vous reporter au Manuel Avancé.

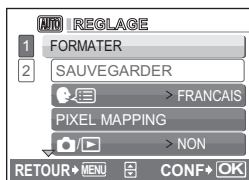

# Prenez des photos

## a. Tenez l'appareil photo.

Tenue horizontale

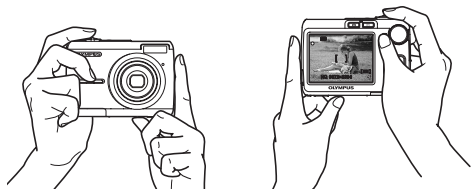

Tenue verticale

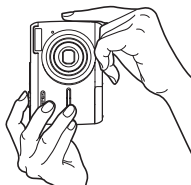

## b. Mise au point.

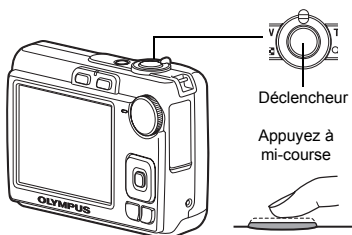

Déclencheur

Appuyez à mi-course

Placez ce repère sur votre sujet.

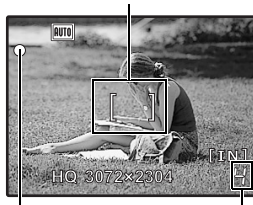

Le nombre de photos restantes s'affiche.

Le voyant vert indique que la mise au point et l'exposition sont mémorisées.

## c. Prendre la photo.

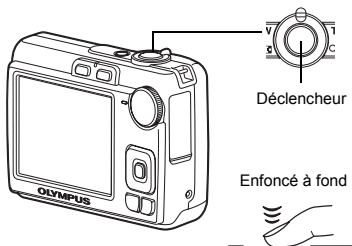

Déclencheur

Enfoncé à fond

Le voyant d'accès de carte clignote.



Fr

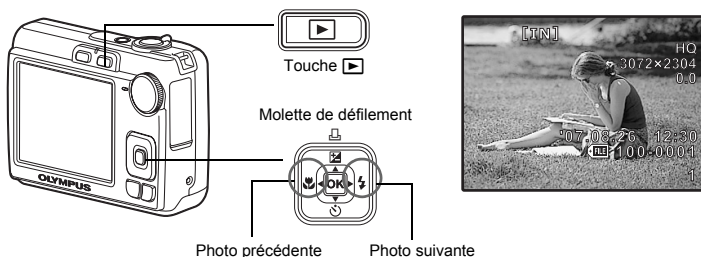

# Vérifier les images

- a. Appuyez sur la touche .





Fr

## Effacer les photos

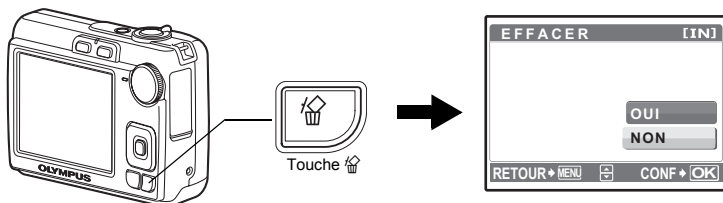
- a. Appuyez sur la touche  et sur la touche  pour afficher l'image que vous voulez effacer.
- b. Appuyez sur la touche .



- c. Appuyez sur la touche  pour sélectionner [OUI] et appuyez sur .

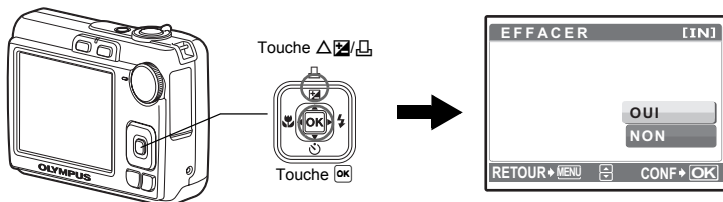

# Fonctionnement de base

## Touches du mode prise de vue

Lorsque vous êtes en mode prise de vue, ces touches vous permettent d'accéder rapidement à certaines des fonctions les plus utilisées.

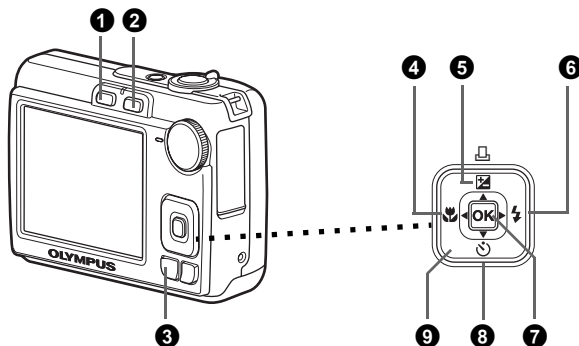

Fr

- 1 Touche (Prise de vue)**  
Sélectionne le mode de prise de vue.
- 2 Touche (Lecture)**  
Sélectionne le mode lecture.
- 3 Touche MENU**  
Appuyez sur cette touche pour afficher le menu principal.
- 4 Touche (Mode Gros Plan)**  
Utilisez le mode gros plan ou super gros plan lorsque vous prenez des photos en gros plan, telle que la photo d'une fleur.
- 5 Touche (Compensation d'exposition/Impression)**  
Appuyez sur cette touche en mode prise de vue pour régler, surexposer [+] ou sousexposer [-] une photo.
- 6 Touche (Mode Flash)**  
Sélectionnez un des quatre modes flash - FLASH AUTO, YEUX ROUGE, FLASH FORCÉ, ou PAS D FLASH.
- 7 Touche**   
Appuyez pour confirmer les réglages.
- 8 Touche (Retardateur)**  
Sélectionnez le retardateur pour retarder la prise de vue d'environ 12 secondes une fois que le déclencheur a été enfoncé.
- 9 Molette de défilement ()**  
Sélectionne les scènes, les photos à visionner et les éléments du menu.

## Molette mode

Sélectionnez le mode souhaité et allumez l'appareil photo. Vous pouvez sélectionner le mode souhaité avant ou pendant l'utilisation.

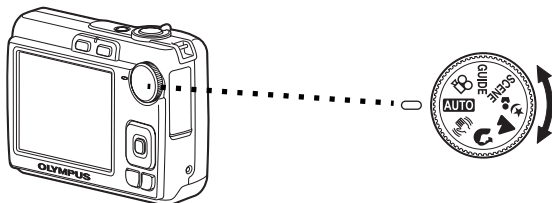

Fr

<b>AUTO</b>	Cette fonction vous permet de procéder à la prise de vue à l'aide des réglages automatiques de l'appareil photo.
	Cette fonction permet de stabiliser les images lors de la prise de vue.
	Convient à des prises de vue de personnes.
	Convient à des prises de vue de paysages.
	Convient à des prises de vue de personnes de nuit.
<b>SCENE</b>	Effectuez une sélection parmi les 10 modes de scène, en fonction des conditions de prise de vue.
	Cette fonction vous permet d'enregistrer des vidéos.
<b>GUIDE</b>	Utilisez le guide de prise de vue affiché à l'écran pour prendre des photos en fonction de la situation.

## Modes SCENE (Scène)

Sélectionnez le mode de prise de vue en fonction d'un objet.

➊ Amenez la molette mode sur **SCENE** et sélectionnez l'autre scène.

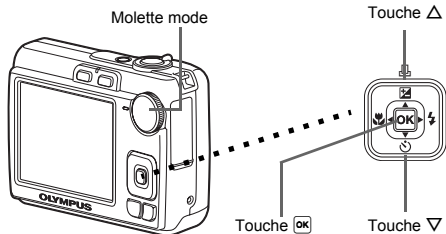
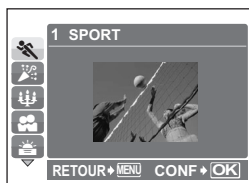

➋ Appuyez sur  $\Delta/\nabla$  pour sélectionner les modes scènes et appuyez sur **OK**.

## Prise de vue en modes SCENE

- SPORT
- INTERIEUR
- BOUGIE
- AUTO PORTRAIT
- COUCHER DE SOLEIL
- FEUX D'ARTIFICES
- VITRINE
- CUISINE
- DOCUMENTS
- ENCHÈRE

### Mode gros plan

- Ce mode vous permet de prendre des photos à 10 cm du sujet. (Côté du plus grand angle)
  - Utilisez ce mode pour prendre des photos à 5 cm de votre sujet. En mode , la position du zoom est fixe.
- 1 Appuyez à plusieurs reprises sur pour sélectionner [] ou [] et appuyez sur .

### Modes flash

- 1 Appuyez à plusieurs reprises sur pour sélectionner le mode flash et appuyez sur .
- 2 Appuyez sur le déclencheur jusqu'à mi-course.
  - Lorsque le flash est réglé pour se déclencher, l'indication s'allume.
- 3 Enfoncez le déclencheur à fond pour prendre la photo.

Icône	Mode flash	Description
<b>AUTO</b>	FLASH AUTO	Le flash se déclenche automatiquement lorsque l'éclairage est faible ou à contre-jour.
	YEUX ROUGE	Une série de pré-éclairs est émise afin de réduire l'effet "yeux rouges" des photos.
	FLASH FORCÉ	Le flash se déclenche quelles que soient les conditions d'éclairage.
	PAS D FLASH	Le flash ne se déclenche pas, même dans des situations de faible éclairage.

## Retardateur

- 1 Appuyez sur  $\nabla$   $\odot$  pour sélectionner  $\odot$  et appuyez sur **OK**.
- 2 Enfoncez le déclencheur à fond pour prendre la photo.
  - Le voyant du retardateur s'allume pendant environ 10 secondes après que le déclencheur ait été enfoncé, puis il clignote. La photo est prise après environ 2 secondes de clignotement.

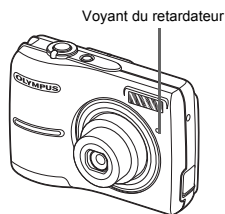

## Fonctionnalité d'économie d'énergie

Fr

- Pour économiser l'énergie de la pile, l'appareil photo passe automatiquement en mode veille et cesse de fonctionner après approximativement 3 minutes d'inactivité. Appuyez sur le déclencheur ou le levier de zoom pour réactiver l'appareil photo.
- Une fois qu'il est entré en mode veille, si l'appareil n'est toujours pas utilisé au bout de 12 minutes, l'objectif se rétracte automatiquement et l'appareil s'éteint. Pour l'utiliser à nouveau, remettez-le sous tension.



# Menus et réglages

## Menu principal

- 1 Appuyez sur **MENU** pour afficher le menu principal.

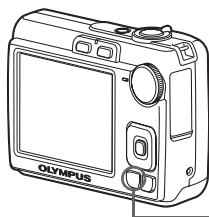

Menu principal en mode prise de vue

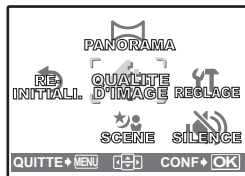

Touche **MENU**

- 2 Utilisez la molette de défilement ( $\Delta/\nabla/\leftarrow/\rightarrow$ ) pour sélectionner les éléments du menu et appuyez sur **OK** pour les régler.

Fr

### PANORAMA

La prise de vue panoramique vous permet de créer une photo panoramique grâce au logiciel OLYMPUS Master contenu dans le CD-ROM fourni. Une carte Olympus xD-Picture Card est nécessaire pour la prise de vue panoramique.

### REINITIAL.

Réinitialisez, à leurs valeurs d'origine, les fonctions de prise de vue qui ont été modifiées.

### QUALITE D'IMAGE

Définissez la qualité des images prises en fonction de l'utilisation prévue.

### REGLAGE

Réglez la date, l'heure, la langue, le son lié au fonctionnement, etc.

### SCENE (Mode scène)

Sélectionnez le mode de scène en fonction du sujet et des conditions de prise de vue lorsque le mode **SCENE** est activé.

### SILENCE

Eteint les sons liés au fonctionnement, pendant la prise de vue et la lecture.

## Effacement de toutes les photos

- 1 Appuyez sur **MENU** en mode lecture pour afficher le menu principal et sélectionnez [EFFACER] > [TOUT EFFAC].
- 2 Sélectionnez [OUI] et appuyez sur **OK**.
  - Toutes les images sont effacées.

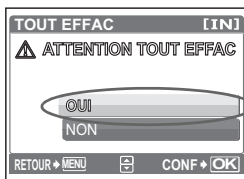





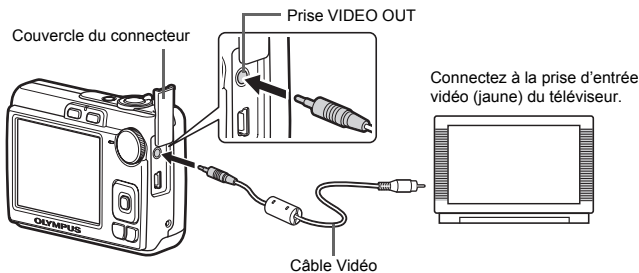

# Connexion de l'appareil photo

## Affichage sur un téléviseur

Utilisez le câble vidéo fourni avec l'appareil photo pour visualiser les images enregistrées directement sur votre téléviseur. Vous pouvez lire ainsi à la fois les images fixes et les vidéos.

- 1 Assurez-vous que le téléviseur et l'appareil photo sont éteints. Connectez la prise VIDEO OUT de l'appareil photo à la prise d'entrée vidéo du téléviseur avec le câble vidéo.



- 2 Allumez le téléviseur et mettez-le en mode entrée vidéo.
  - Pour en savoir plus sur le passage en entrée vidéo, veuillez consulter le mode d'emploi du téléviseur.
- 3 Mettez l'appareil sous tension et appuyez ensuite sur  pour passer en mode lecture.
  - La dernière photo prise est affichée sur le téléviseur. Utilisez la molette de défilement (///) pour sélectionner la photo à afficher.

## Impression directe (PictBridge)

Le câble USB fourni vous permet de connecter directement l'appareil photo à une imprimante compatible PictBridge pour procéder aux impressions.

Vous pouvez de manière très simple, imprimer une photo.

- 1 En mode lecture, affichez à l'écran la photo que vous souhaitez imprimer.
- 2 Connectez une des extrémités du câble USB dans le connecteur de l'appareil photo et l'autre dans le connecteur USB de l'imprimante.

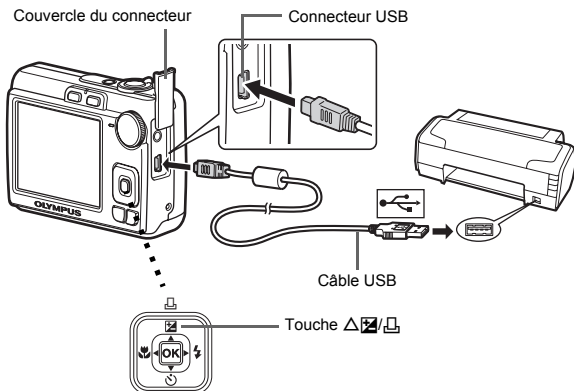

- 3 Appuyez sur Δ/☒/☐.
  - L'impression démarre.
  - Lorsque l'impression est terminée, déconnectez le câble USB de l'appareil photo avec l'écran de sélection des photos affiché.



# Transfert d'images

## Installez le logiciel

- 1 Insérez le CD-ROM OLYMPUS Master.
- 2 **Windows:** Cliquez sur le bouton "OLYMPUS Master 2".  
**Macintosh:** Double-cliquez sur l'icône "Setup".
- 3 Suivez simplement les instructions à l'écran.



## Connectez l'appareil photo à l'ordinateur

Fr

- 1 Connectez l'appareil photo et l'ordinateur à l'aide du câble USB (fourni).
  - L'écran ACL s'allume automatiquement.

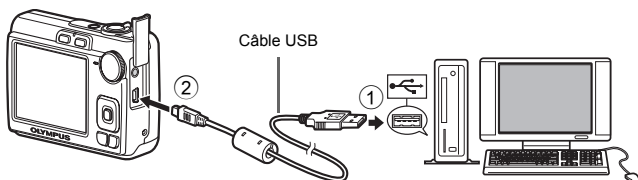

- 2 Sélectionnez [PC] sur l'écran ACL et appuyez sur **OK**.

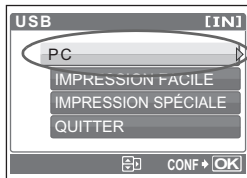

- Votre ordinateur reconnaît maintenant votre appareil photo comme unité de stockage amovible.

## Transférez les images vers l'ordinateur

- 1 Gardez votre appareil photo connecté, puis ouvrez OLYMPUS Master.
- 2 Cliquez sur "Transférer des images" dans la fenêtre Parcourir, puis cliquez sur "Depuis l'appareil photo" .
- 3 Suivez simplement les instructions à l'écran.

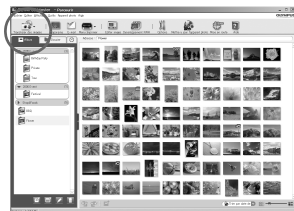

Fr

## Conseils

- Pour des informations plus détaillées concernant la configuration et l'utilisation de l'appareil photo, veuillez consulter le "Manuel Avancé" de l'appareil, fourni sur CD-ROM.
- Pour plus d'information, consultez le fichier d'"Aide" du logiciel OLYMPUS Master.

# Logiciel OLYMPUS Master

Logiciel OLYMPUS Master: Utilisez ce logiciel pour télécharger des photos à partir de l'appareil photo, pour afficher, organiser, retoucher, envoyer par courrier électronique et imprimer vos photos et vidéos numériques, etc.



## ● Configurations système minimales

SE	Windows 2000 Professional/XP Home Edition/XP Professional/Vista ou Mac OS X (v10.3 ou ultérieur)
UC	Pentium III 500 MHz/Power PC G3 500 MHz/Intel Core Solo/Duo 1,5 GHz ou supérieur
RAM	256 Mo ou plus
Capacité du disque dur	500 Mo ou plus
Connexion	Port USB/Port IEEE 1394 (FireWire)
Écran ACL	Résolution de 1024 × 768 pixels ou plus avec un minimum de 65.536 couleurs (Windows), 32.000 couleurs (Macintosh)
Autres	Internet Explorer 6 ou ultérieur (Windows) Safari 1.0 ou ultérieur, QuickTime 6 ou ultérieur (Macintosh)

Fr

Pour obtenir les dernières informations relatives à la prise en charge, consultez le site internet Olympus  
(<http://www.olympus.com/digital>)



### Enregistrement de l'utilisateur

Enregistrez votre appareil photo lorsque vous installez OLYMPUS Master pour activer la garantie, recevoir des notifications de logiciel et les mises à jours de micro-logiciels et plus encore.

## ● Appareil photo

Type de produit	: Appareil photo numérique (prise de vue et affichage)
Système d'enregistrement	
Photos	: Enregistrement numérique, JPEG (conforme à la norme DCF (Design rule for Camera File system))
Normes applicables	: Exif 2.2, Digital Print Order Format (DPOF), PRINT Image Matching III, PictBridge
Vidéo	: AVI Motion JPEG
Mémoire	: Mémoire interne xD-Picture Card (16 Mo à 2 Go) (Type H/M, Standard)
Nombre de pixels effectifs	: 7 100 000 de pixels
Capteur d'image	: CCD 1/2,5" (filtre des couleurs primaires), 7 400 000 pixels (brut)
Objectif	: Objectif Olympus 6,3 à 18,9 mm, f3,1 à 5,9 (équivalent à un objectif de 38 mm à 114 mm sur un appareil photo de 35 mm)
Système de mesure	: Métrage pondéré au centre
Vitesse d'obturation	: 4 à 1/2 000 sec.
Portée de prise de vue	: 0,6 m à ∞ (W), 1,0 m à ∞ (T) (normal) 0,1 m à ∞ (W), 0,6 m à ∞ (T) (mode gros plan) 0,05 m à ∞ (mode super gros plan)
Écran ACL	: Écran couleur à cristaux liquides TFT de 2,5", 154 000 pixels
Connecteurs externes	: Prise d'entrée CC (DC-IN), Connecteur USB, Prise VIDEO OUT
Calendrier automatique	: de 2000 à 2099
Conditions de fonctionnement	
Température	: 0°C à 40°C (fonctionnement)/ -20°C à 60°C (stockage)
Humidité	: 30% à 90% (fonctionnement)/ 10% à 90% (stockage)
Alimentation	: Batteries AA, 2 de chaque type (batteries Oxyride/ Alkaline/NiMH) ou adaptateur spécifié AC
Dimensions	: 90 mm (L) × 62,5 mm (H) × 30,5 mm (P) (hors saillies)
Poids	: 122 g (sans batterie et carte)

Veillez noter que des améliorations de conception et de spécifications peuvent entraîner des modifications sans préavis.

# Précautions de sécurité



## ATTENTION

RISQUE DE DÉCHARGE  
ÉLECTRIQUE NE PAS OUVRIR



**ATTENTION:** POUR RÉDUIRE LE RISQUE DE DÉCHARGE ÉLECTRIQUE, NE RETIRER NI LA PARTIE ANTERIEURE NI POSTERIEURE DU BOÎTIER. AUCUNE PIÈCE À L'INTÉRIEUR NE PEUT ÊTRE RÉPARÉE PAR L'UTILISATEUR. SE RÉFÉRER À DU PERSONNEL DE DÉPANNAGE QUALIFIÉ POUR UNE RÉPARATION.



Le point d'exclamation à l'intérieur d'un triangle vous alerte sur certains points importants concernant le maniement et l'entretien de l'appareil figurant dans la documentation fournie avec le produit.



### DANGER

Si le produit est utilisé sans respecter les informations données sous ce symbole, des blessures graves, voire mortelles pourraient en résulter.



### AVERTISSEMENT

Si le produit est utilisé sans respecter les informations données sous ce symbole, des blessures voire la mort pourraient en résulter.



### ATTENTION

Si le produit est utilisé sans observer les informations données sous ce symbole, des blessures, des dommages à l'appareil ou des pertes de données pourraient en résulter.

#### AVERTISSEMENT !

POUR ÉVITER LES RISQUES D'INCENDIE OU DE DÉCHARGE ÉLECTRIQUE, NE JAMAIS DÉMONTER, EXPOSER CE PRODUIT À L'EAU NI LE FAIRE FONCTIONNER DANS UN ENVIRONNEMENT TRÈS HUMIDE.

## Précautions générales

**Lire toutes les instructions** — Avant d'utiliser l'appareil, lire toutes les instructions de fonctionnement. Sauvegarder tous les manuels et la documentation pour s'y référer ultérieurement.

**Nettoyage** — Toujours débrancher ce produit de la prise de courant avant nettoyage. N'utiliser qu'un chiffon humide pour le nettoyage. Ne jamais utiliser de produits de nettoyage liquides ou aérosols, ni de solvants organiques pour nettoyer ce produit.

**Accessoires** — Pour votre sécurité, et pour éviter d'endommager le produit, n'utiliser que des accessoires recommandés par Olympus.

**Eau et humidité** — Pour les précautions sur des produits avec une conception imperméable, lire les sections imperméabilisation.

**Emplacement** — Pour éviter d'endommager l'appareil, monter le produit solidement sur un trépied ou un sabot stable.

**Alimentation** — Ne raccorder ce produit qu'à la source d'alimentation décrite sur l'étiquette du produit.

**Foudre** — Si un orage éclate pendant l'utilisation d'un adaptateur secteur, le débrancher immédiatement de la prise de courant.

**Entrée d'objets** — Pour éviter des blessures, ne jamais introduire d'objet métallique dans le produit.

**Chaleur** — Ne jamais utiliser ni ranger ce produit près d'une source de chaleur telle qu'un radiateur, un accumulateur de chaleur, ou tout type d'appareil qui génère de la chaleur, comprenant les amplificateurs.



## Maniement de l'appareil



### AVERTISSEMENT

- **Ne pas utiliser l'appareil à proximité de gaz inflammables ou explosifs.**
- **Ne pas utiliser le flash de très près sur des personnes (bébés, jeunes enfants, etc.).**
  - Vous devez être au moins à 1 m des visages de vos sujets. Déclencher le flash trop près des yeux du sujet pourrait causer une perte momentanée de la vision.
- **Ne pas laisser l'appareil à la portée des enfants.**
  - Toujours utiliser et ranger l'appareil hors de la portée des jeunes enfants et des bébés pour empêcher les situations dangereuses suivantes qui pourraient causer des blessures graves :
    - S'enrouler dans la courroie de l'appareil, causant la strangulation.
    - Avaler accidentellement la batterie, des cartes ou d'autres petites pièces.
    - Déclencher accidentellement le flash dans leurs yeux ou ceux d'un autre enfant.
    - Se blesser accidentellement par des parties en mouvement de l'appareil.
- **Ne pas regarder le soleil ni de la lumière puissante avec l'appareil.**
- **Ne pas utiliser ni ranger l'appareil dans des endroits poussiéreux ou humides.**
- **Ne pas couvrir le flash avec une main pendant le déclenchement.**

Fr



### ATTENTION

- **Arrêter immédiatement d'utiliser l'appareil si vous remarquez une odeur, un bruit anormal ou de la fumée provenant de l'appareil.**
  - Ne jamais retirer les batteries les mains nues, ce qui pourrait vous brûler les mains.
- **Ne jamais manipuler l'appareil avec des mains mouillées.**
- **Ne pas laisser l'appareil dans des endroits où il pourrait être soumis à des températures très élevées.**
  - Ceci pourrait causer une détérioration de certaines pièces et, dans certaines circonstances, l'appareil pourrait prendre feu. Ne pas utiliser le chargeur ni un adaptateur secteur s'il est couvert (par exemple par une couverture). Ce qui pourrait causer une surchauffe, débouchant sur un incendie.
- **Manipuler l'appareil soigneusement afin d'éviter une brûlure à basse température.**
  - Lorsque l'appareil contient des parties métalliques, une surchauffe peut déboucher sur une brûlure à basse température. Faire attention aux points suivants :
    - Utilisé pendant une longue durée, l'appareil devient chaud. Si vous tenez l'appareil dans ces conditions, une brûlure à basse température risque de se produire.
    - Dans des endroits sujets à des températures très froides, la température du corps de l'appareil peut être plus basse que la température ambiante. Si possible, mettre des gants en tenant l'appareil à des températures basses.

● **Faire attention avec la courroie.**

- Faire attention avec la courroie en portant l'appareil. Elle peut facilement s'accrocher à des objets sur le passage et causer des dommages sérieux.

**Précautions de manipulation de la batterie**

**Veillez suivre ces consignes importantes pour éviter le coulage du liquide de la batterie, une génération de chaleur, des brûlures, une explosion, ou de causer des décharges électriques ou brûlures.**



**DANGER**

- Utiliser uniquement des piles NiMH de marque Olympus et le chargeur correspondant.
- Ne jamais chauffer ni mettre au feu des piles.
- Prendre des précautions en transportant ou rangeant des piles pour éviter qu'elles viennent en contact avec des objets métalliques comme des bijoux, des épingles à cheveux, des agrafes, etc.
- Ne jamais ranger des piles où elles seraient exposées en plein soleil, ou sujettes à des températures élevées dans un véhicule chaud, près d'une source de chaleur, etc.
- Pour éviter de causer des coulages de liquide de pile ou d'endommager leurs bornes, respecter scrupuleusement toutes les instructions concernant l'usage des piles. Ne jamais tenter de démonter une pile ni la modifier, en soudant, etc.
- Si du liquide de pile entrain dans vos yeux, les laver immédiatement avec de l'eau claire et froide du robinet et consulter immédiatement un médecin.
- Toujours ranger les piles hors de la portée des jeunes enfants. Si un enfant avale accidentellement une pile, consulter immédiatement un médecin.



**AVERTISSEMENT**

- Maintenir à tout moment les piles au sec.
- Pour éviter un coulage du liquide des piles, une génération de chaleur ou de causer un incendie ou une explosion, n'utiliser que les piles recommandées pour l'utilisation avec ce produit.
- Ne jamais mélanger des piles/batteries (piles neuves et usagées, batteries chargées et déchargées, piles/batteries de fabricant ou de capacité différente, etc.).
- Ne pas charger des piles alcalines ou au lithium si elles ne sont pas rechargeables.
- Insérer soigneusement la pile comme indiqué dans les instructions de fonctionnement.
- Ne pas utiliser de piles dont le corps n'est pas recouvert d'une feuille isolante ou si la feuille est déchirée, cela pourrait causer une fuite de liquide, un incendie ou des blessures.

**ATTENTION**

- Ne pas retirer les piles immédiatement après avoir utilisé l'appareil photo. Les piles peuvent devenir chaudes lors d'une utilisation prolongée.
- Toujours retirer la batterie de l'appareil avant de le ranger pour une longue durée.

- Les piles AA suivantes ne peuvent pas être utilisées.

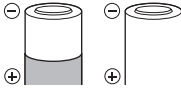

Piles dont le corps n'est que partiellement recouvert ou pas du tout recouvert par une feuille isolante.



Piles dont la borne  $\ominus$  est relevée, mais pas recouverte par une feuille isolante.

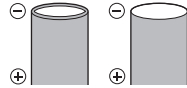

Piles dont les bornes sont plates et pas complètement recouvertes par une feuille isolante. (De telles piles ne peuvent pas être utilisées même si la borne  $\ominus$  est partiellement recouverte.)

- Si des piles NiMH ne sont pas chargées au bout de la durée spécifiée, arrêter de les charger et ne pas les utiliser.
- Ne pas utiliser une batterie si elle est endommagée ou cassée.
- Si une pile fuit, se décolore ou se déforme, ou présente tout autre aspect anormal, arrêter d'utiliser l'appareil photo.
- Si du liquide de pile coule sur vos vêtements ou sur votre peau, retirer le vêtement et laver immédiatement la zone affectée avec de l'eau claire et froide du robinet. Si le liquide vous brûle la peau, consulter immédiatement un médecin.
- Ne jamais soumettre les piles à des chocs violents ni à des vibrations continues.

**Pour les utilisateurs aux États-Unis**

Déclaration de conformité

Numéro du modèle:FE-210/X-775

Nom de marque:OLYMPUS

Partie responsable:OLYMPUS IMAGING AMERICA INC.

Adresse:3500 Corporate Parkway, P.O. Box 610, Center Valley, PA  
18034-0610, U.S.A.

Numéro de téléphone:484-896-5000

Déclaré conforme aux normes FCC

POUR UNE UTILISATION AU BUREAU OU A DOMICILE

Cet appareil est conforme à la section 15 de la réglementation FCC. Le fonctionnement est soumis aux deux conditions suivantes:

- (1) Cet appareil ne peut générer d'interférences nuisibles.
- (2) Cet appareil doit accepter toutes les interférences reçues, les interférences pouvant occasionner un fonctionnement non souhaité incluses.

**Pour les utilisateurs au Canada**

Cet appareil numérique de classe B répond à toutes les exigences des réglementations canadiennes relatives aux équipements générant des interférences.

Fr

**Marques déposées**

- IBM est une marque déposée de la société International Business Machines Corporation.
- Microsoft et Windows sont des marques déposées de la société Microsoft Corporation.
- Macintosh est une marque de Apple Computer Inc.
- xD-Picture Card™ est une marque déposée.
- Tous les autres noms de sociétés et appellations de produits sont des marques, déposées ou non, des propriétaires respectifs.
- Les normes pour les systèmes de fichiers d'appareil photo indiquées dans ce manuel sont les normes "Design Rule for Camera File System/DCF" stipulées par l'association JEITA (Japan Electronics and Information Technology Industries Association).

---

## Memo

# Tabla de contenidos

<b>Reúna estos componentes (contenido de la caja)</b> .....	<b>55</b>
<b>Inserte las pilas</b> .....	<b>56</b>
<b>Encienda la cámara</b> .....	<b>57</b>
<b>Ajuste de la fecha y hora</b> .....	<b>58</b>
<b>Seleccionar un idioma</b> .....	<b>60</b>
<b>Tome una fotografía</b> .....	<b>61</b>
<b>Revise sus fotografías</b> .....	<b>62</b>
<b>Utilización básica</b> .....	<b>63</b>
Botones del modo de fotografía.....	63
Disco de modo.....	64
Modos de <b>SCENE</b> (Escenas) .....	64
Modo macro.....	65
Modos de flash .....	65
Disparador automático.....	66
Función de ahorro de energía .....	66
<b>Menús y ajustes</b> .....	<b>67</b>
Menú superior.....	67
Borrar todas las fotografías .....	67
<b>Conexión de la cámara</b> .....	<b>68</b>
Reproducción en un televisor .....	68
Impresión directa (PictBridge) .....	69
<b>Transferencia de imágenes</b> .....	<b>70</b>
<b>Software OLYMPUS Master</b> .....	<b>72</b>
<b>Especificaciones</b> .....	<b>73</b>
<b>Precauciones de seguridad</b> .....	<b>74</b>
● Antes de utilizar la cámara, lea atentamente este manual para poder utilizarla correctamente.	
● Antes de tomar fotografías importantes, le recomendamos que realice varias tomas de prueba para familiarizarse con el uso de su cámara.	
● Le rogamos observe todas las precauciones de seguridad que figuran al final de este manual.	
● Las imágenes de la pantalla LCD y las ilustraciones de la cámara que se usan en este manual pueden diferir del producto real.	

# Reúna estos componentes (contenido de la caja)



Cámara digital



Correa



Pilas tipo AA  
(2)

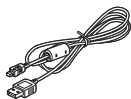

Cable USB

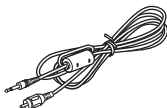

Cable de señal de vídeo



OLYMPUS Master CD-ROM

## Otros artículos

- Manual Básico (este manual)
  - Manual Avanzado
  - Tarjeta de garantía
- Los contenidos pueden variar dependiendo del lugar de compra.

Es

## Colocación de la correa

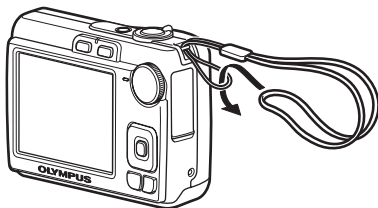

- Tire de la correa para que quede apretada y no se suelte.

# Inserte las pilas

a. Inserte las pilas en la cámara.

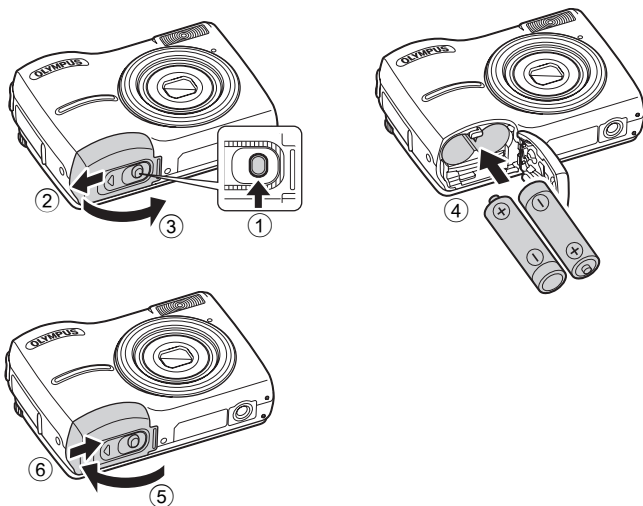

Es

- Puede tomar una fotografía incluso si no está insertada la tarjeta xD-Picture Card™ (en lo sucesivo denominada la tarjeta). Para obtener más información sobre cómo insertar una tarjeta opcional, consulte el Manual Avanzado.

## Consejo

En el manual de instrucciones suministrado se indica la dirección de las teclas de control ( $\Delta$   $\nabla$   $\triangleleft$   $\triangleright$ ) con  $\Delta$   $\nabla$   $\triangleleft$   $\triangleright$ .

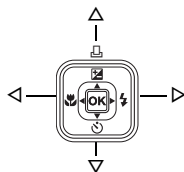



# Encienda la cámara

Aquí se explica cómo encender la cámara en el modo de fotografía.

## a. Sitúe el disco de modo en **AUTO**.

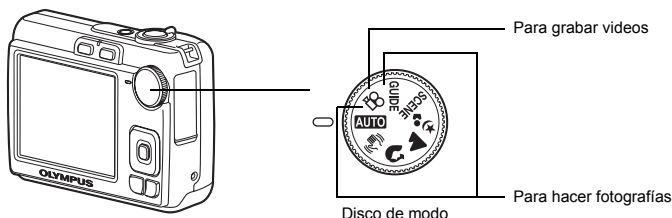

### Modos de toma de fotografías

<b>AUTO</b>	Esta función le permite tomar fotografías con los ajustes automáticos de la cámara.
	Esta función estabiliza la imagen al tomar fotografías.
	Adecuado para fotografiar personas.
	Apropiado para fotografiar paisajes.
	Adecuado para fotografiar personas por la noche.
<b>SCENE</b>	Selección de entre 10 modos de escena según las condiciones de fotografía.
<b>GUIDE</b>	Utilice la toma de imágenes que se muestra en la pantalla para fotografiar según la situación.

Es

## b. Presione el botón POWER.

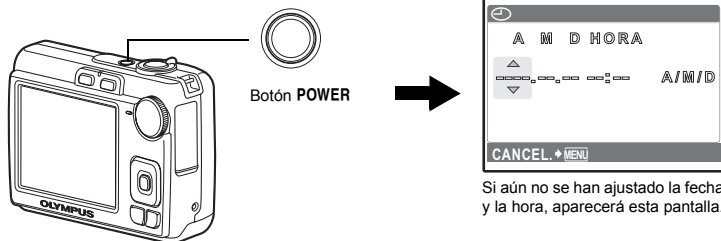

- Para apagar la cámara, vuelva a presionar el botón **POWER**.

# Ajuste de la fecha y hora

## Acerca de la pantalla de ajuste de la fecha y hora

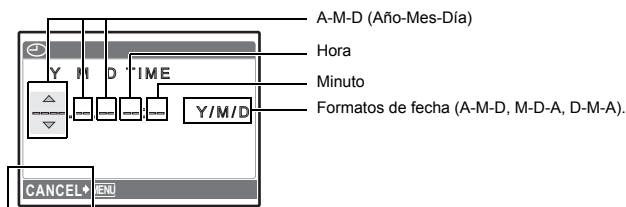

Para cancelar el ajuste

- a. Presione el botón y el botón para seleccionar [A].

Es

- Los dos primeros dígitos de [A] son fijos.

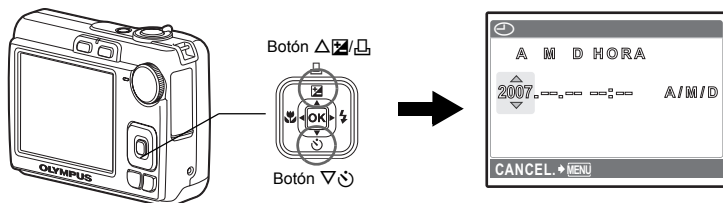



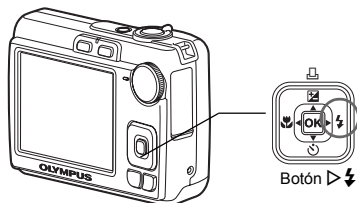

- b. Presione el botón .







- c. Presione el botón y el botón para seleccionar [M].







- d. Presione el botón .
- e. Presione el botón /  y el botón  para seleccionar [D].



- f. Presione el botón .
- g. Presione el botón /  y el botón  para seleccionar “hora”, “minutos”.

- La hora se muestra en el formato de 24 horas.



- h. Presione el botón .
- i. Presione el botón /  y el botón  para seleccionar [A/M/D].



Es

- j. Una vez hechos todos los ajustes, presione el botón .

- Para un ajuste horario preciso, presione el botón  cuando la señal horaria alcance los 00 segundos.

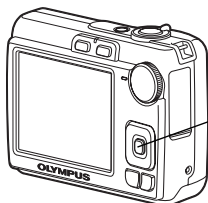

# Seleccionar un idioma

- a. Presione el botón MENU para ver el menú superior.

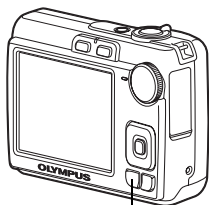

Botón MENU

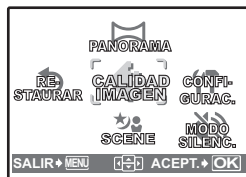



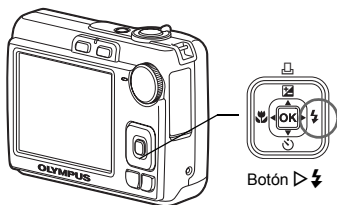

- b. Presione el botón  para seleccionar [CONFIGURAC.] y presione el botón .

Es

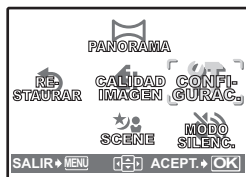





Botón 



- c. Presione el botón  y el botón  para seleccionar , y presione el botón .



- d. Utilice las teclas de control (, , , ) para seleccionar un idioma y presione el botón .

- Se pueden añadir otros idiomas a la cámara con el software OLYMPUS Master suministrado. Consulte el Manual Avanzado.

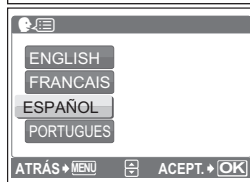

# Tome una fotografía

## a. Sujete la cámara.

Sujeción horizontal

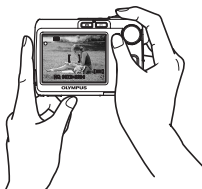
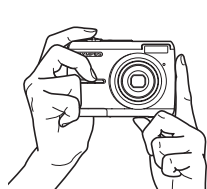

Sujeción vertical

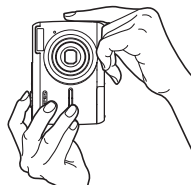

## b. Enfoque.

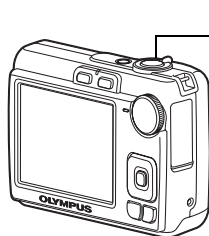

Botón disparador

Presionar a medias



Coloque esta marca sobre el sujeto.



En la pantalla se muestra el número de fotografías restantes.

El piloto verde indica que el enfoque y la exposición están bloqueados.

Es

## c. Dispare.

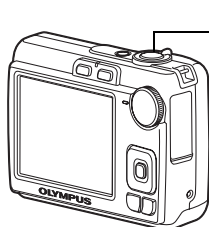

Botón disparador

Presionar completamente



El piloto de control de la tarjeta parpadea.



# Revise sus fotografías

a. Presione el botón .

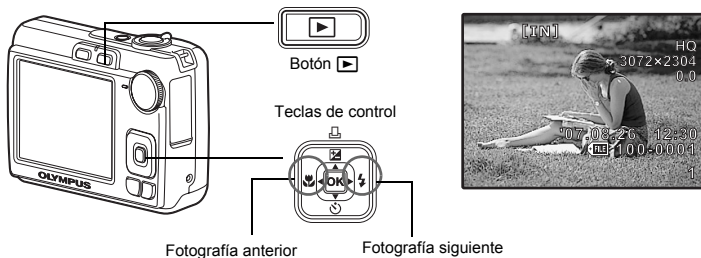

## Borrar las imágenes

Es

a. Presione el botón  y el botón  para ver la fotografía que desea borrar.

b. Presione el botón .

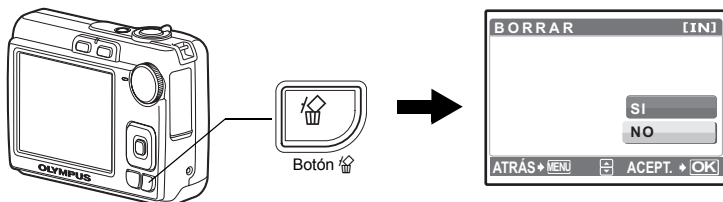

c. Presione el botón  para seleccionar [SI] y luego presione el botón .

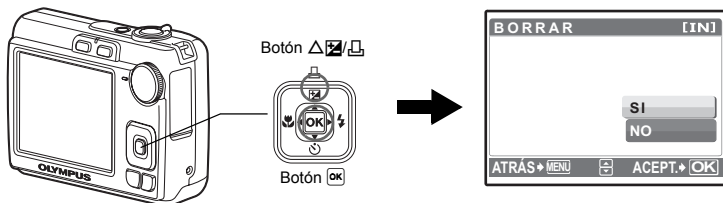







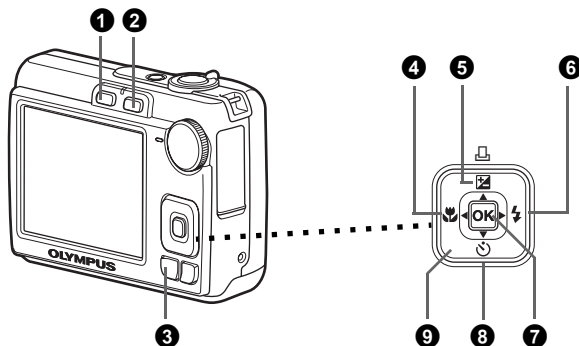







# Utilización básica

## Botones del modo de fotografía

En el modo de fotografía, puede usar estos botones para acceder rápidamente a las funciones más habituales.



Es

- 1 Botón  (fotografía)**  
Selecciona el modo de fotografía.
- 2 Botón  (reproducción)**  
Selecciona el modo de reproducción.
- 3 Botón MENU**  
Presione este botón para abrir el menú superior.
- 4 Botón  (modo macro)**  
Utilice el modo macro o supermacro cuando tome fotografías de primeros planos, por ejemplo, de una flor.
- 5 Botón  /  (Compensación de exposición/Imprimir)**  
Presione este botón en el modo de fotografía para sobreexponer [+] o subexponer [-] una fotografía.
- 6 Botón  (modo de flash)**  
Seleccione uno de los 4 modos de flash: FLASH AUTO,  OJOS ROJOS,  DE RELLENO,  APAGADO.
- 7 Botón **  
Presione para confirmar los ajustes.
- 8 Botón  (Disparador automático)**  
Seleccione el disparador automático para retrasar la toma 12 segundos aproximadamente desde el momento de presionar el botón disparador.
- 9 Teclas de control (   )**  
Selecciona escenas, reproduce fotografías y selecciona opciones de menú.

## Disco de modo

Seleccione el modo deseado y encienda la cámara. Los modos se pueden seleccionar antes de encender la cámara o durante su uso.

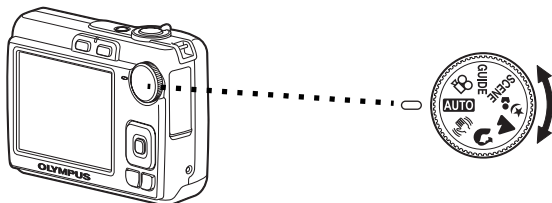

<b>AUTO</b>	Esta función le permite tomar fotografías con los ajustes automáticos de la cámara.
	Esta función estabiliza la imagen al tomar fotografías.
	Adecuado para fotografiar personas.
	Apropiado para fotografiar paisajes.
	Adecuado para fotografiar personas por la noche.
<b>SCENE</b>	Seleccione de entre 10 modos de escena según las condiciones de fotografía.
	Esta función le permite filmar vídeos.
<b>GUIDE</b>	Utilice la toma de imágenes que se muestra en la pantalla para fotografiar según la situación.

Es

## Modos de SCENE (Escenas)

Elija el modo de fotografía según un objeto.

- 1 Sitúe el disco de modo en **SCENE** y seleccione la otra escena.

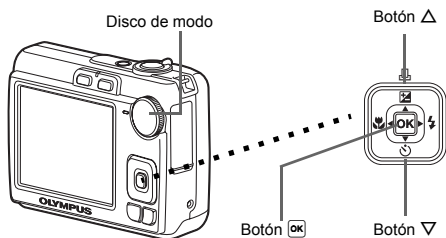

- 2 Presione  $\Delta/\nabla$  para seleccionar los modos de escenas y luego presione  $\square$ .



## Modos de ESCENA para fotografía

- DEPORTE
- PUESTA SOL
- COCINA
- INTERIORES
- FUEG.ARTIF.
- DOCUMENTOS
- VELAS
- VITRINA
- SUBASTA
- AUTO - RETRATO

### Modo macro

- Este modo le permite fotografiar a una distancia de 10 cm del sujeto. (Lado de gran angular máximo)
  - Utilice este modo para tomar fotografías a una distancia de 5 cm del sujeto. En el modo la posición del objetivo zoom está fijada.
- 1 Presione varias veces para seleccionar [] o [] y presione .

### Modos de flash

- 1 Presione varias veces para seleccionar el modo de flash y luego presione .
- 2 Presione a medias el botón disparador.
  - Si el flash está ajustado para dispararse, se ilumina la marca .
- 3 Presione el botón disparador a fondo para tomar la fotografía.

Es

Icono	Modo de flash	Descripción
<b>AUTO</b>	FLASH AUTO	El flash se dispara automáticamente en condiciones de baja iluminación o de contraluz.
	OJOS ROJOS	Se emiten predestellos para la reducción del fenómeno de ojos rojos.
	DE RELLENO	El flash se dispara independientemente de la luz disponible.
	APAGADO	El flash no se dispara, aun en condiciones de baja iluminación.

## Disparador automático

- 1 Presione  $\nabla$   $\odot$  para seleccionar [ $\odot$ ] y luego presione **OK**.
- 2 Presione el botón disparador a fondo para tomar la fotografía.
  - El LED del disparador automático se ilumina durante unos 10 segundos después de presionar el botón disparador, luego empieza a parpadear. Tras parpadear durante 2 segundos aproximadamente, se toma la fotografía.

LED del disparador automático

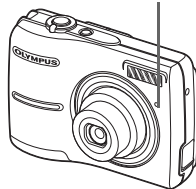

## Función de ahorro de energía

- Para ahorrar energía de la batería, la cámara entra automáticamente en el modo de reposo y deja de funcionar después de unos aproximado 3 minutos de inactividad. Presione el botón disparador o el mando de zoom para reactivar la cámara.
- Si la cámara no se utiliza durante 12 minutos después de entrar en el modo de reposo, se retrae automáticamente el objetivo y se apaga. Para volver a utilizarla, enciéndala otra vez.

# Menús y ajustes

## Menú superior

- 1 Presione **MENU** para abrir el menú superior.

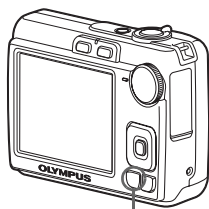

Menú superior en modo de fotografía

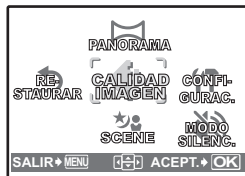

- 2 Utilice las teclas de control ( $\Delta$ / $\nabla$ / $\leftarrow$ / $\rightarrow$ ) para seleccionar opciones de menú, y presione **OK** para ajustarlas.

### PANORAMA

Le permite crear fotografías panorámicas mediante el software OLYMPUS Master del CD-ROM suministrado. Para tomar fotografías panorámicas hace falta una tarjeta Olympus xD-Picture Card.

### RESTAURAR

Restaura los valores de los ajustes de fábrica.

### CALIDAD IMAGEN

Ajuste la calidad de la imagen que va a capturar según la finalidad de la fotografía.

### CONFIGURAC.

Ajuste la fecha y la hora, el idioma, el sonido de funcionamiento, etc.

### SCENE (Modo de escena)

Seleccione el modo de escena en función del sujeto y las condiciones fotográficas con el modo **SCENE** seleccionado.

### MODO SILENC.

Silencia los sonidos de funcionamiento que se producen durante las operaciones de fotografía y reproducción.

Es

## Borrar todas las fotografías

- 1 Presione **MENU** en modo de reproducción para ver el menú superior y seleccione **[BORRAR] > [BORRAR TODO]**.
- 2 Seleccione **[SI]** y presione **OK**.
  - Se borran todas las fotografías.



# Conexión de la cámara



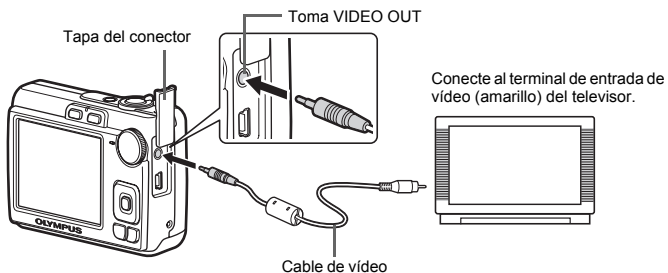

## Reproducción en un televisor

Emplee el cable de vídeo suministrado con la cámara para reproducir imágenes grabadas en el televisor. Puede reproducir tanto fotografías como vídeos.

- 1 Compruebe que el televisor y la cámara estén apagados. Conecte la toma VIDEO OUT de la cámara al terminal de entrada de vídeo del televisor usando el cable de vídeo suministrado.



Es

- 2 Encienda el televisor y cambie al modo de entrada de vídeo.
  - Para obtener más información sobre la manera de cambiar la entrada de vídeo, consulte el manual de instrucciones del televisor.
- 3 Encienda la cámara y presione  para entrar en el modo de reproducción.
  - En el televisor aparecerá la última fotografía tomada. Utilice las teclas de control (///) para seleccionar la fotografía que desea ver.

## Impresión directa (PictBridge)

Mediante el cable USB, puede conectar su cámara directamente a una impresora compatible con el estándar PictBridge para realizar copias.

Puede imprimir una fotografía mediante operaciones sencillas.

- 1 En el modo de reproducción, localice en el monitor la fotografía que desea imprimir.
- 2 Conecte un extremo del cable USB suministrado al conector USB de la cámara y el otro extremo al conector USB de la impresora.

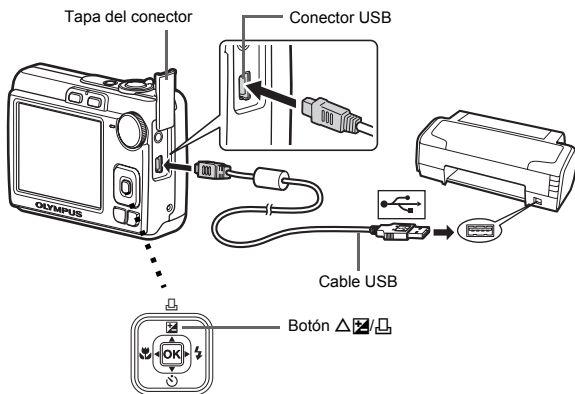

- 3 Presione  $\Delta$   $\square$   $\square$ .
  - Se inicia la impresión.
  - Cuando haya terminado, desconecte el cable USB de la cámara con la pantalla de selección de fotografías activa.



# Transferencia de imágenes

## Instalar el software

- 1 Inserte el CD-ROM de OLYMPUS Master.
- 2 **Windows:** Haga clic en el botón "OLYMPUS Master 2".  
**Macintosh:** Haga doble clic en el icono "Setup".
- 3 Siga las instrucciones en pantalla.



## Conecte la cámara a un ordenador

- 1 Conecte la cámara y el ordenador usando el cable USB (incluido).
  - El monitor se encenderá automáticamente.

Es

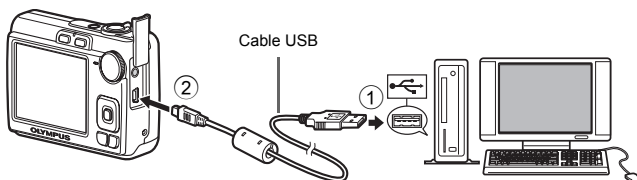

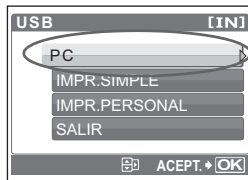

- 2 Seleccione [PC] en el monitor y presione **OK**.



- Ahora el ordenador reconocerá su cámara como una unidad de almacenamiento extraíble.

## Transfiera las imágenes al ordenador

- 1 Ahora, con la cámara conectada, abra el programa OLYMPUS Master.
- 2 Haga clic en "Transferir imágenes"  en la ventana de examinar y haga clic en "De cámara" .
- 3 Siga las instrucciones en pantalla.

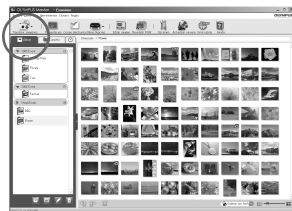

Es

## Consejos

- Para obtener información más detallada acerca de la configuración y el uso de la cámara, consulte el "Manual Avanzado" de la cámara que se incluye en el CD-ROM.
- Si necesita ayuda adicional, consulte el archivo "Ayuda" del software OLYMPUS Master.

# Software OLYMPUS Master

Software OLYMPUS Master: ¡Utilice este software para descargar fotografías desde la cámara, ver, organizar, retocar, imprimir y mandar por correo electrónico e imprimir sus fotos digitales, vídeos y mucho más!



## ● Requisitos del sistema

SO	Windows 2000 Professional/XP Home Edition/XP Professional/Vista o Mac OS X (v10.3 o posterior)
CPU	Pentium III 500 MHz/Power PC G3 500 MHz/Intel Core Solo/Duo, 1,5 GHz o posterior
RAM	256 MB o más
Capacidad del disco duro	500 MB o más
Conexión	Puerto USB/Puerto IEEE 1394 (FireWire)
Monitor	1024 × 768 píxeles de resolución o más con un mínimo de 65.536 colores (Windows), 32.000 colores (Macintosh)
Otros	Internet Explorer 6 o posterior (Windows) Safari 1.0 o posterior, QuickTime 6 o posterior (Macintosh)

Es

Para obtener la información de asistencia más actualizada, visite el sitio Web de Olympus  
(<http://www.olympus.com/digital>)



### Registro de usuario

Registre su cámara cuando instale OLYMPUS Master para activar su garantía, recibir notificaciones sobre actualizaciones de software y firmware de la cámara, y mucho más.



## ● Cámara

Tipo de producto	: Cámara digital (para fotografía y reproducción)
Sistema de grabación	
Fotografías	: Grabación digital, JPEG (según la norma Design rule for Camera File system (DCF))
Estándares aplicables	: Exif 2.2, Formato de reserva de impresión digital (DPOF), PRINT Image Matching III, PictBridge
Vídeo	: AVI Motion JPEG
Memoria	: Memoria interna xD-Picture Card (16 MB - 2 GB) (Type H/M, Standard)
Número de píxeles efectivos	: 7.100.000 píxeles
Dispositivo de captura de imagen	: CCD de 1/2,5" (filtro de colores primarios), 7.400.000 píxeles (brutos)
Objetivo	: Objetivo Olympus 6,3 a 18,9 mm, f3,1 a 5,9 (equivalente a un objetivo de 38 a 114 mm en una cámara de 35 mm)
Sistema fotométrico	: Sistema de medición centrada
Velocidad de obturación	: 4 a 1/2000 seg.
Alcance de fotografía	: 0,6 m a $\infty$ (W), 1,0 m a $\infty$ (T) (normal) 0,1 m a $\infty$ (W), 0,6 m a $\infty$ (T) (modo macro) 0,05 m a $\infty$ (modo supermacro)
Monitor	: Pantalla LCD TFT en color de 2,5", 154.000 píxeles
Conector exterior	: Jack DC-IN, conector USB, toma VIDEO OUT
Sistema de calendario automático	: 2000 hasta 2099
Entorno de funcionamiento	
Temperatura	: 0°C a 40°C (funcionamiento)/ -20°C a 60°C (almacenamiento)
Humedad	: 30% a 90 % (funcionamiento)/ 10% a 90 % (almacenamiento)
Fuente de alimentación	: 2 baterías tipo AA cada una (baterías Oxyride/baterías alcalinas/baterías NiMH) o un adaptador de CA especificado
Dimensiones	: 90 mm (ancho) × 62,5 mm (altura) × 30,5 mm (prof.) (sin salientes)
Peso	: 122 g (sin batería ni tarjeta)

Tenga presente que los cambios por mejoras de diseño y especificaciones pueden realizarse sin aviso previo.

# Precauciones de seguridad



## PRECAUCIÓN

RIESGO DE DESCARGAS  
ELÉCTRICAS  
NO ABRIR



**PRECAUCIÓN** : PARA REDUCIR EL RIESGO DE DESCARGAS ELÉCTRICAS, NO RETIRE LA CUBIERTA (O PARTE TRASERA). EN EL INTERIOR NO HAY PIEZAS QUE EL USUARIO PUEDA REPARAR. REMITA LA REPARACIÓN A PERSONAL DE SERVICIO ESPECIALIZADO OLYMPUS.



El signo de admiración dentro de un triángulo equilátero tiene como finalidad alertar al usuario de la existencia de importantes instrucciones de operación y mantenimiento en la documentación suministrada con el producto.



### PELIGRO

Si el producto es utilizado sin observar la información representada bajo este símbolo, podría causar serias lesiones o muerte.



### ADVERTENCIA

Si el producto es utilizado sin observar la información representada bajo este símbolo, podría causar serias lesiones o muerte.



### PRECAUCIÓN

Si el producto es utilizado sin observar la información representada bajo este símbolo, podría causar lesiones personales menores, daños al equipo, o pérdida de datos importantes.

#### ¡ADVERTENCIA!

PARA EVITAR EL RIESGO DE INCENDIO O DESCARGAS ELÉCTRICAS, NUNCA DESMONTE NI EXPONGA ESTE PRODUCTO AL AGUA NI LO UTILICE EN UN ENTORNO MUY HÚMEDO.

Es

## Precauciones Generales

**Lea todas las instrucciones** — Antes de utilizar este producto, lea todas las instrucciones operativas. Guarde todos los manuales y la documentación para futuras consultas.

**Limpieza** — Siempre desenchufe el producto de la toma de corriente antes de limpiarlo. Para la limpieza use sólo un paño húmedo. Nunca use limpiadores líquidos o aerosoles, ni solventes orgánicos de ningún tipo para limpiar este producto.

**Accesorios** — Para su seguridad y evitar daños al producto, utilice únicamente los accesorios recomendados por Olympus.

**Agua y humedad** — En las precauciones de los productos diseñados a prueba de la intemperie, consulte las secciones de resistencia a la intemperie en sus respectivos manuales.

**Ubicación** — Para evitarle daños al producto, monte el producto sobre un trípode, caballete o soporte estable.

**Fuentes de alimentación** — Conecte este producto únicamente con la fuente de alimentación descrita en la etiqueta del producto.

**Rayos** — Si se produce una tormenta eléctrica mientras está utilizando el adaptador de CA, retírelo de la toma de corriente inmediatamente.

**Objetos extraños** — Para evitar daños personales, nunca inserte objetos de metal en el producto.

**Calentadores** — Nunca utilice ni guarde este producto cerca de fuentes de calor, tales como radiadores, rejillas de calefacción, estufas o cualquier tipo de equipo o aparato generador de calor, incluyendo amplificadores estéreo.

## Manejo de la cámara



### ADVERTENCIA

- **No utilice la cámara cerca de gases inflamables o explosivos.**
- **No utilice el flash a corta distancia de las personas (especialmente niños menores y mayores, etc.).**
  - Cuando dispare el flash, deberá mantener, por lo menos, una distancia de 1 m de la cara de los sujetos. El disparo demasiado cercano de los ojos del sujeto podrá causarle la pérdida de visión momentánea.
- **Mantenga a los niños menores y mayores alejados de la cámara.**
  - Utilice y guarde siempre la cámara fuera del alcance de los niños menores y mayores, para prevenir las siguientes situaciones de peligro que podrían causarles serias lesiones:
    - Enredarse con la correa de la cámara, ocasionando asfixia.
    - Ingerir accidentalmente una batería, tarjetas, u otras piezas pequeñas.
    - Disparar el flash accidentalmente hacia sus propios ojos o hacia los ojos de otro niño.
    - Lesionarse accidentalmente con las piezas móviles de la cámara.
- **No mire al sol ni a luces fuertes a través de la cámara.**
- **No utilice ni guarde la cámara en lugares polvorientos o húmedos.**
- **No cubra el flash con la mano mientras efectúa el disparo.**



### PRECAUCIÓN

- **Interrumpa inmediatamente el uso de la cámara si percibe algún olor, ruido o humo extraño alrededor de la misma.**
  - Nunca retire las baterías con las manos descubiertas, ya que podría causar un incendio o quemarle las manos.
- **Nunca sujete ni utilice la cámara con las manos mojadas.**
- **No deje la cámara en lugares donde pueda estar sujeta a temperaturas extremadamente altas.**
  - Si lo hace puede provocar el deterioro de las piezas y, en algunas circunstancias, provocar que se prenda fuego. No utilice el cargador o el adaptador CA si está cubierto (por ejemplo con una frazada). Esto podría causar recalentamiento, resultando en incendio.
- **Manipule la cámara con cuidado para evitar una quemadura de leve.**
  - Ya que la cámara contiene partes metálicas, el recalentamiento puede resultar en una quemadura de baja temperatura. Preste atención a lo siguiente:
    - Cuando utilice la cámara durante un largo período, ésta se recalentará. Si mantiene la cámara en este estado, podría causar una quemadura de baja temperatura.
    - En lugares sujetos a temperaturas extremadamente bajas, la temperatura de la carcasa de la cámara puede ser más baja que la temperatura ambiente. Si es posible, póngase guantes cuando manipule la cámara en temperaturas bajas.

● **Tenga cuidado con la correa.**

- Tenga cuidado con la correa cuando transporte la cámara. Podría engancharse en objetos sueltos y provocar daños graves.

**Precauciones acerca del uso de la batería**

**Siga estas importantes indicaciones para evitar que se produzcan fugas, recalentamientos, incendios o explosión de la batería, o que cause descargas eléctricas o quemaduras.**



**PELIGRO**

- Utilice únicamente baterías NiMH de la marca Olympus y el cargador correspondiente.
- Nunca caliente ni incinere las pilas.
- Tome precauciones al transportar o guardar las pilas a fin de evitar que entren en contacto con objetos metálicos, tales como alhajas, horquillas, cierres, etc.
- Nunca guarde las pilas en lugares donde queden expuestas a la luz solar directa o sujetas a altas temperaturas en el interior de un vehículo con calefacción, cerca de fuentes de calor, etc.
- Para evitar que ocurran fugas de líquido de las pilas o daños de sus terminales, siga cuidadosamente todas las instrucciones respectivas al uso de las pilas. Nunca intente desarmar una pila ni modificarla de ninguna manera, por soldadura, etc.
- Si el fluido de la pila penetrara en sus ojos, lávelos de inmediato con agua corriente fresca y limpia, y solicite atención médica inmediatamente.
- Siempre guarde las pilas fuera del alcance de los niños menores. Si un niño ingiere una pila accidentalmente, solicite atención médica inmediatamente.

Es



**ADVERTENCIA**

- Conserve las pilas siempre secas.
- Para evitar que ocurran fugas de líquido, recalentamiento de las pilas, o que causen incendio o explosión, utilice únicamente las pilas recomendadas para este producto.
- Nunca mezcle las pilas (pilas nuevas con usadas, pilas cargadas con descargadas, pilas de distinta marca o capacidad, etc.).
- No intente cargar las baterías alcalinas o la pila de litio si no son recargables.
- Inserte la batería con cuidado como se describe en las instrucciones operativas.
- No utilice baterías si el cuerpo no está cubierto con una lámina aislante o si dicha lámina está perforada, ya que podría provocar fugas de líquido, incendio o lesión.



## PRECAUCIÓN

- No retire las baterías inmediatamente después de utilizar la cámara. Las baterías pueden recalentarse durante el uso prolongado.
- Siempre retire la batería de la cámara antes de guardar la cámara por un largo tiempo.

- Las siguientes pilas AA no pueden ser utilizadas.

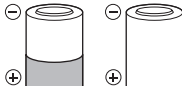

Pilas parcialmente cubiertas o no cubiertas totalmente por una hoja aislante.



Pilas con terminales  $\ominus$  en relieve, pero no cubiertos por una hoja aislante.

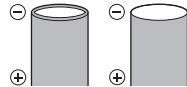

Pilas con terminales planos, pero no completamente cubiertos por una hoja aislante (Tales pilas no pueden ser usadas aunque los terminales  $\ominus$  estén parcialmente cubiertos).

- Si las pilas de NiMH no se recargan dentro del tiempo especificado, interrumpa la recarga de las mismas y no las use.
- No utilice una pila si está rajada o quebrada.
- Si se producen fugas de líquido, decoloración o deformación de la batería, o cualquier otra anomalía durante la operación, interrumpa el uso de la cámara.
- Si el fluido de la pila entrara en contacto con su ropa o con su piel, quítese la ropa y lave de inmediato la parte afectada con agua corriente fresca y limpia. Si el fluido quemara su piel, solicite atención médica inmediatamente.
- Nunca exponga la pila a fuertes impactos ni a vibraciones continuas.

Es

## Para los clientes de Norte y Sudamérica

### Para clientes de Estados Unidos

Declaración de conformidad

Número de modelo: FE-210/X-775

Marca comercial : OLYMPUS

Parte responsable : OLYMPUS IMAGING AMERICA INC.

Dirección : 3500 Corporate Parkway, P.O. Box 610, Center Valley,  
PA 18034-0610, U.S.A.

Número de teléfono: 484-896-5000

Este equipo cumple con la normativa FCC

PARA EL USO EN EL HOGAR O LA OFICINA

Este equipo cumple con la Parte 15 de la normativa FCC. Su uso está sujeto a las dos condiciones siguientes:

(1) Este equipo no debe causar interferencias dañinas.

(2) Este equipo debe aceptar cualquier interferencia recibida, incluidas las interferencias que puedan causar un funcionamiento no deseado.

### Para clientes de Canadá

Este equipo digital de Clase B cumple con los requisitos de la normativa canadiense sobre equipos que provocan interferencias.

Es

## Marcas comerciales

- IBM es una marca registrada de International Business Machines Corporation.
- Microsoft y Windows son marcas registradas de Microsoft Corporation.
- Macintosh es una marca comercial de Apple Computer Inc.
- xD-Picture Card™ es una marca comercial.
- Todos los demás nombres de compañías y productos son marcas registradas y/o marcas comerciales de sus respectivos propietarios.
- Las normas para sistemas de archivos de cámara referidas en este manual son las "Normas de Diseño para Sistema de Archivos de Cámara/DCF" estipuladas por la Asociación de Industrias Electrónicas y de Tecnología de Información de Japón (JEITA).

---

## Memo

# Índice

<b>Reunir estes itens (conteúdo da embalagem)</b> .....	<b>81</b>
<b>Inserir as pilhas</b> .....	<b>82</b>
<b>Ligar a câmara</b> .....	<b>83</b>
<b>Acertar data e hora</b> .....	<b>84</b>
<b>Seleccionar um idioma</b> .....	<b>86</b>
<b>Fotografar</b> .....	<b>87</b>
<b>Ver as suas imagens</b> .....	<b>88</b>
<b>Funcionamento básico</b> .....	<b>89</b>
Botões do Modo Fotografia .....	89
Selector de modo.....	90
Modos SCENE (Cena).....	90
Modo Macro.....	91
Modos Flash .....	91
Temporizador.....	92
Função de poupança de energia .....	92
<b>Menus e parâmetros</b> .....	<b>93</b>
Menu superior.....	93
Apagar todas as imagens .....	93
<b>Ligar a câmara</b> .....	<b>94</b>
Reprodução num televisor.....	94
Impressão directa (PictBridge) .....	95
<b>Transferir imagens</b> .....	<b>96</b>
<b>Software OLYMPUS Master</b> .....	<b>98</b>
<b>Especificações</b> .....	<b>99</b>
<b>Precauções de segurança</b> .....	<b>100</b>
● Antes de utilizar a sua câmara, leia este manual atentamente para garantir uma utilização correcta.	
● Recomendamos que tire fotografias de teste para se habituar à câmara, antes de tirar fotografias importantes.	
● Respeite as precauções de segurança apresentadas no final deste manual.	
● As imagens do ecrã LCD e as ilustrações da câmara utilizadas neste manual podem diferir do produto real.	



# Reunir estes itens (conteúdo da embalagem)



Câmara Digital



Correia



Pilhas AA  
(2)

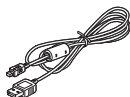

Cabo USB

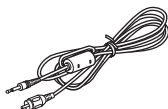

Cabo de vídeo



CD-ROM OLYMPUS  
Master

## Outros itens

- Manual Básico (este manual)
  - Manual Avançado
  - Cartão de garantia
- O conteúdo pode variar conforme o local de aquisição.

Pt

## Colocar a correia

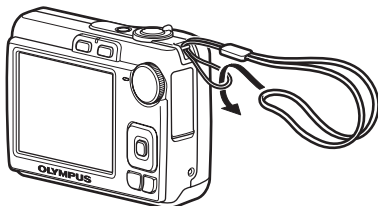

- Puxe bem a correia de modo a que não fique solta.

# Inserir as pilhas

## a. Insira as pilhas na câmara.

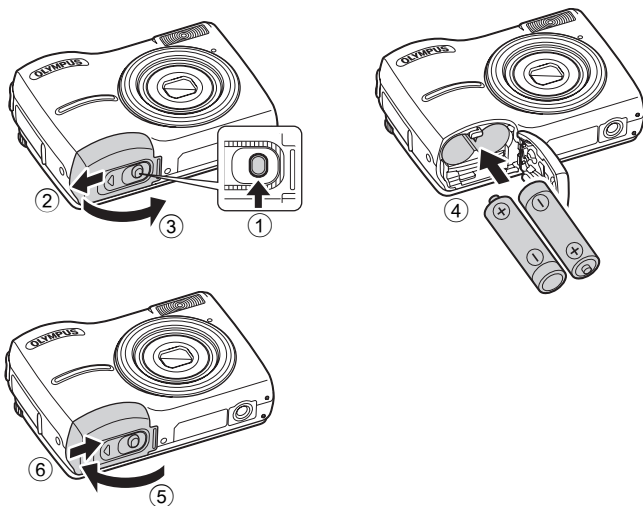

Pt

- Mesmo quando um cartão xD-Picture Card™ (designado a partir de aqui apenas por cartão) não estiver inserido, pode tirar fotografias. Quanto aos detalhes sobre a inserção de um cartão opcional, consulte o Manual Avançado.

### Sugestão

As direcções do selector em cruz ( $\Delta \nabla \triangleleft \triangleright$ ) estão indicadas, neste manual, com  $\Delta \nabla \triangleleft \triangleright$ .

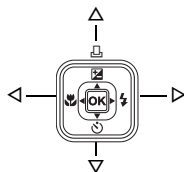

# Ligar a câmara

Este modo explica como ligar a câmara no modo fotografia.

## a. Ajuste o selector de modo para **AUTO**.

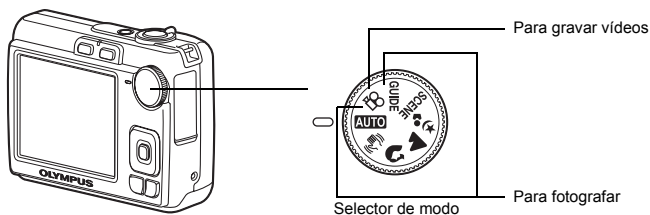

### Modos de fotografia

<b>AUTO</b>	Esta função permite tirar fotografias com as definições automáticas da câmara.
	Esta função estabiliza as imagens ao tirar fotografias.
	Indicado para fotografar fotografias tipo retrato.
	Indicado para fotografar paisagens.
	Indicado para fotografar pessoas à noite.
<b>SCENE</b>	Selecionar de entre 10 modos de cena mediante as condições fotográficas.
<b>GUIDE</b>	Usar o assistente de fotografia, visualizado no ecrã, para fotografar imagens mediante a situação.

Pt

## b. Prima o botão **POWER**.

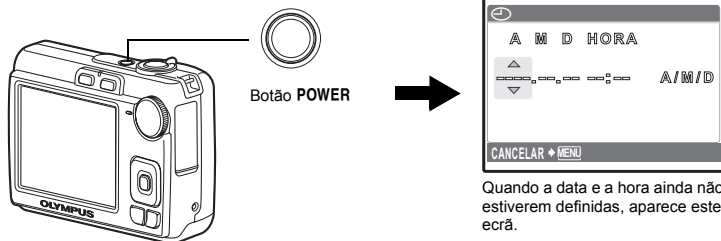

Quando a data e a hora ainda não estiverem definidas, aparece este ecrã.

- Para desligar a câmara, premir novamente o botão **POWER**.

# Acertar data e hora

## Acerca do ecrã de acerto da data e da hora

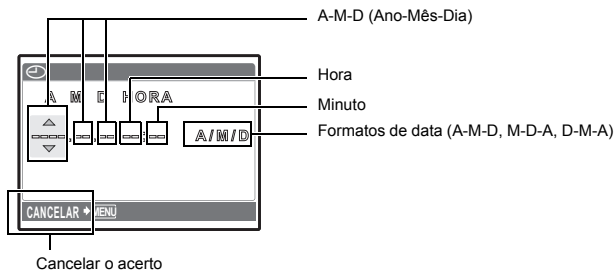

a. Prima o botão  $\Delta$   $\square$   $\square$  e o botão  $\nabla$   $\odot$  para seleccionar [A].

- Os primeiros dois dígitos de [A] são fixos.

Pt

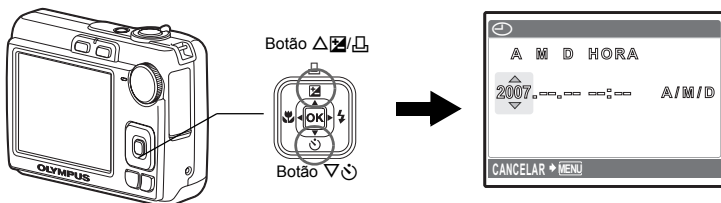

b. Prima o botão  $\triangleright$   $\square$ .

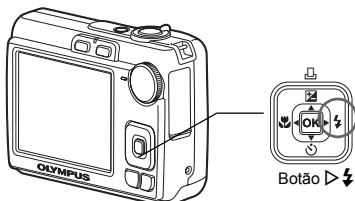

c. Prima o botão  $\Delta$   $\square$   $\square$  e o botão  $\nabla$   $\odot$  para seleccionar [M].



d. Prima o botão  $\triangleright$   $\square$ .

e. Prima o botão  e o botão  para seleccionar [D].



f. Prima o botão .

g. Prima o botão  e o botão  para seleccionar “hora” e “minuto”.

- A hora é exibida no formato de 24 horas.



h. Prima o botão .

i. Prima o botão  e o botão  para seleccionar [A/M/D].



Pt

j. Depois de configuradas todas as definições, prima o botão .

- Para definir a hora exacta, prima o botão  até que o sinal da hora atinja os 00 segundos.

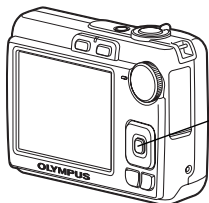

# Seleccionar um idioma

- a. Prima o botão MENU para exibir o menu superior.

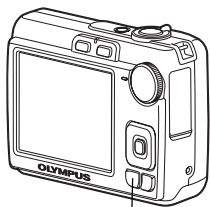

Botão MENU

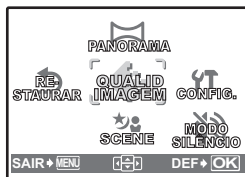

- b. Prima o botão  $\triangleright \downarrow$  para seleccionar [CONFIG.] e prima o botão  $\square$  OK.

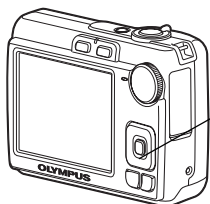

Botão  $\triangleright \downarrow$

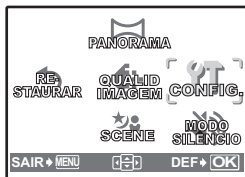

- c. Prima o botão  $\triangle \uparrow$  e o botão  $\nabla \downarrow$  para seleccionar [PORTUGUES] e prima o botão  $\square$  OK.

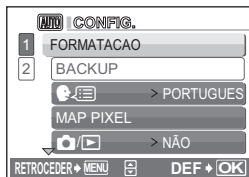

- d. Utilizar o selector em cruz ( $\triangle \nabla \triangleleft \triangleright$ ) para seleccionar o idioma e prima o botão  $\square$  OK.

- Pode-se adicionar outros idiomas à câmara com o software OLYMPUS Master fornecido. Consulte o Manual Avançado.



# Fotografar

## a. Segurar a câmara.

Segurar na horizontal

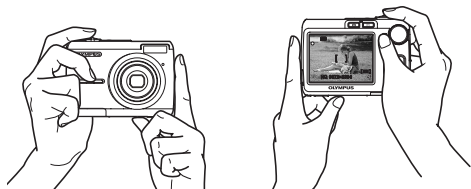

Segurar na vertical

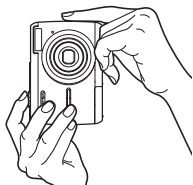

## b. Focar.

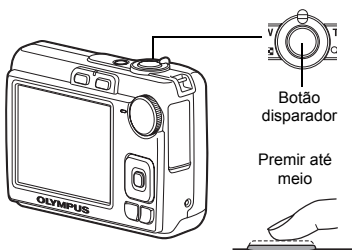

Posicione esta marca sobre o seu motivo fotográfico.



É visualizado o número de imagens disponíveis para fotografar.



A luz verde indica que a focagem e a exposição estão bloqueadas.

Pt

## c. Fotografar.

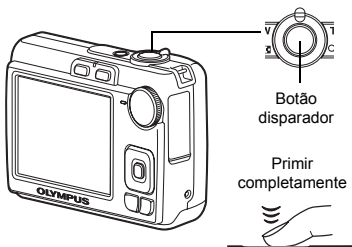

A luz de acesso de cartão pisca.



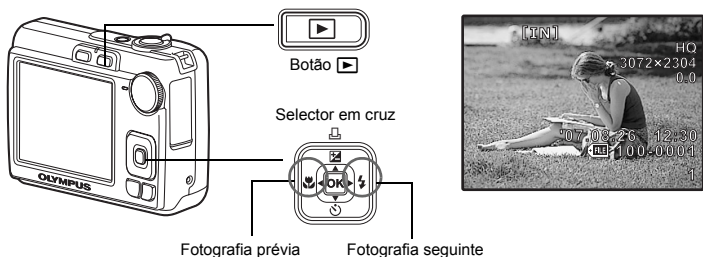

# Ver as suas imagens

a. Prima o botão .







## Apagar imagens

a. Prima o botão  e o botão  de modo a visualizar a imagem que pretende apagar.

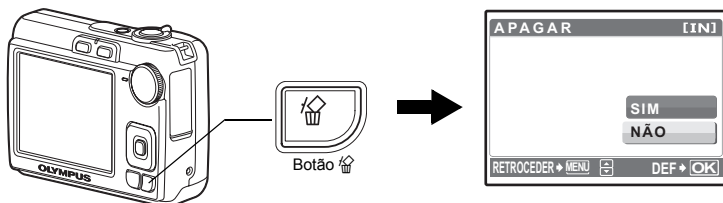
b. Prima o botão .

Pt



c. Prima o botão /  para seleccionar [SIM] e então prima o botão .

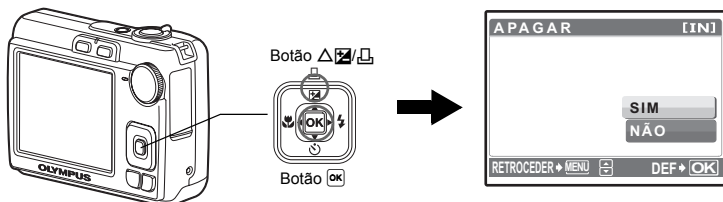



# Funcionamento básico

## Botões do Modo Fotografia

No Modo Fotografia, utilize estes botões para obter um acesso rápido a algumas das funções mais frequentemente utilizadas.

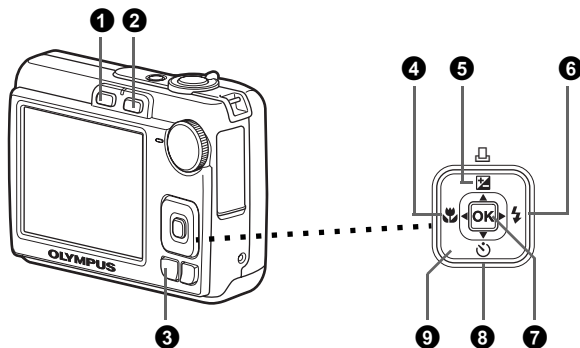

- 1 Botão (fotografar)**  
Selecciona o modo fotografia.
- 2 Botão (Reprodução)**  
Selecciona o modo reprodução.
- 3 Botão MENU**  
Premir esta botão para visualizar o menu superior.
- 4 Botão (Modo Macro)**  
Utilize o modo macro ou super macro para fotografar grandes planos como, por exemplo, de uma flor.
- 5 Botão (Compensação da exposição/Imprimir)**  
Prima este botão no modo fotografia para regular o aumento [+] ou diminuição [-] da exposição de uma fotografia.
- 6 Botão (Modo Flash)**  
Selecione entre um dos 4 modos flash - FLASH AUTO, OLHOS VERM., FILL IN ou FLASH DESL.
- 7 Botão OK**  
Prima para confirmar as definições.
- 8 Botão (Temporizador)**  
Selecione o temporizador para atrasar o disparo cerca de 12 segundos a partir do momento em que o botão disparador é premido.
- 9 Selector em cruz ()**  
Selecciona cenas, imagens de reprodução e parâmetros do menu.

Pt

## Selector de modo

Defina o modo desejado e accione a câmara. Pode-se seleccionar o modo desejado antes ou durante a utilização.

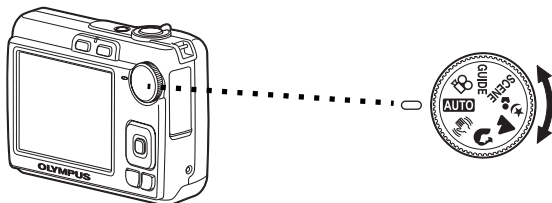

<b>AUTO</b>	Esta função permite tirar fotografias com as definições automáticas da câmara.
	Esta função estabiliza as imagens ao tirar fotografias.
	Indicado para fotografar fotografias tipo retrato.
	Indicado para fotografar paisagens.
	Indicado para fotografar pessoas à noite.
<b>SCENE</b>	Seleccionar de entre 10 modos de cena mediante as condições fotográficas.
	Esta função permite-lhe gravar vídeos.
<b>GUIDE</b>	Usar o assistente de fotografia, visualizado no ecrã, para fotografar imagens mediante a situação.

Pt

## Modos SCENE (Cena)

Selecione o modo de fotografia de acordo com o motivo fotográfico.

1 Ajuste o selector de modo para **SCENE** e selecione uma cena diferente.

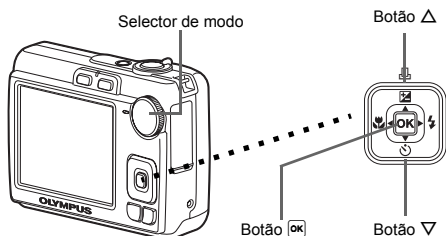

2 Prima  $\Delta/\nabla$  para seleccionar os modos de cena e prima  $\square$ .

## Modos SCENE (Cena) de fotografia

- DESPORTO
- PÔR-DO-SOL
- CULINÁRIA
- INTERIORES
- FOGOS ARTIF
- DOCUMENTOS
- VELA
- ATRÁS DE VIDRO
- MODO CENA
- AUTO-RETRATO

### Modo Macro

- Este modo permite-lhe fotografar imagens a uma proximidade de até 10 cm do seu motivo fotográfico. (Lado do extremo grande angular)
  - Utilize este modo para fotografar imagens a uma proximidade de 5 cm do seu motivo fotográfico. No modo , a posição da objectiva zoom é fixa.
- 1 Prima repetidamente para seleccionar [] ou [] e então prima .



### Modos Flash

- 1 Prima repetidamente para seleccionar o modo flash e então prima .
- 2 Prima o botão disparador até o meio.
  - Quando o flash for ajustado para disparar, a marca se acenderá.
- 3 Prima totalmente o botão disparador para fotografar.

Pt

Ícone	Modo Flash	Descrição
<b>AUTO</b>	FLASH AUTO	O flash dispara automaticamente em condições de luz fraca ou contraluz.
	OLHOS VERM.	Esta opção emite pré-flashes para reduzir o aparecimento dos olhos vermelhos nas fotografias.
	FILL IN	O flash dispara independentemente da luz disponível.
	FLASH DESL.	O flash não dispara mesmo em situações de luz fraca.

## Temporizador

- 1 Prima  para seleccionar [] e prima .
- 2 Prima totalmente o botão disparador para fotografar.
  - A luz temporizador acende-se durante aproximadamente 10 segundos depois de o botão disparador ser premido e então começa a piscar. Depois de piscar durante aproximadamente 2 segundos, a imagem é fotografada.



## Função de poupança de energia

- Para economizar a alimentação, a câmara entra automaticamente em modo de pausa e pára de funcionar se não for usada por aproximadamente 3 minutos. Opere com o botão disparador ou com alavanca do zoom para reacender a câmara.
- Se a câmara não for utilizada durante 12 minutos após entrar em modo inactivo, a objectiva é recolhida e a câmara desliga-se automaticamente. Para voltar a utilizar a câmara, ligue-a novamente.

# Menus e parâmetros

## Menu superior

- 1 Prima **MENU** para exibir o menu superior.

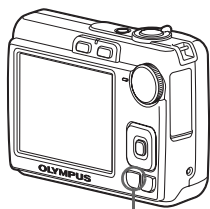

Botão **MENU**

Menu superior no modo fotografia

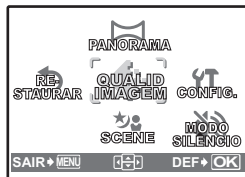

- 2 Utilize o selector em cruz ( $\Delta/\nabla/\leftarrow/\rightarrow$ ) para seleccionar parâmetros do menu e então prima **OK** para defini-los.

### PANORAMA

A fotografia panorâmica permite-lhe criar uma imagem panorâmica, por meio do software OLYMPUS Master do CD-ROM fornecido. Um cartão xD-Picture Card Olympus é requerida para fotografias panorâmicas.

### RESTAURAR

Retorne as funções de fotografia alteradas de volta às suas predefinições de fábrica.

### QUALID IMAGEM

Ajuste a qualidade da imagem que pretende fotografar de acordo com a sua finalidade.

### CONFIG.

Acerte a data, a hora, o idioma, o som operativo, etc.

### SCENE (Mode cena)

Ao seleccionar o modo **SCENE**, faça-o de acordo com o tema fotográfico e a condição da fotografia.

### MODO SILÊNCIO

Desliga os sons operativos que ocorrem durante o registo fotográfico e a reprodução.

## Apagar todas as imagens

- 1 Prima **MENU** no modo reprodução para exibir o menu superior e seleccionar [APAGAR] > [APAGAR IMAGS].
- 2 Selecciona [SIM] e prima **OK**.
  - Todas as imagens são apagadas.

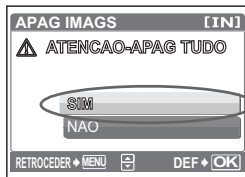

# Ligar a câmara

## Reprodução num televisor

Utilize o cabo de vídeo fornecido com a câmara para reproduzir imagens gravadas no seu televisor. É possível reproduzir tanto fotografias quanto filmes.

- 1 Certifique-se de que o televisor e a câmara estão desligados. Ligar a entrada VIDEO OUT da câmara ao terminal de entrada de vídeo do televisor por meio do cabo de vídeo.

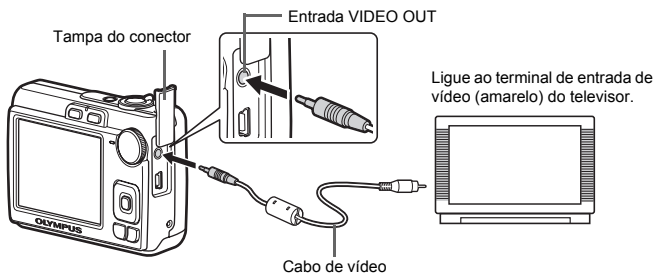

Pt

- 2 Ligue o televisor e defina-o para o modo de entrada de vídeo.
  - Para obter detalhes sobre como comutar para a entrada de vídeo, consulte o manual de instruções do seu televisor.
- 3 Accione a câmara e então prima para entrar no modo reprodução.
  - A última imagem fotografada é visualizada no televisor. Utilize o selector em cruz (>/</img alt="seta para esquerda"/>>)/</img alt="seta para baixo"/>> para seleccionar a imagem que deseja exibir.

## Impressão directa (PictBridge)

Usando o cabo USB fornecido, pode ligar a sua câmara directamente a uma impressora compatível com PictBridge para imprimir as fotografias.

Pode-se imprimir uma fotografia com simples operações.

- 1 No modo de reprodução, exiba no monitor a imagem que deseja imprimir.
- 2 Ligue uma extremidade do cabo USB fornecido ao conector USB da câmara e a outra extremidade ao conector USB da impressora.

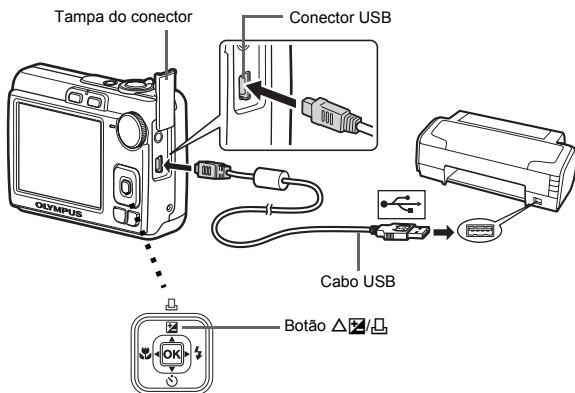

Pt

- 3 Prima  $\Delta$  [ícone de impressão] / [ícone de cancelamento].
  - A impressão começa.
  - Quando tiver terminado de imprimir, desligue o cabo USB da câmara com o ecrã de selecção de imagens exibido.



# Transferir imagens

## Instalar o software

- 1 Insira o CD-ROM OLYMPUS Master.
- 2 **Windows:** Faça um clique no botão "OLYMPUS Master 2".  
**Macintosh:** Faça duplo clique no ícone "Setup".
- 3 Basta seguir as instruções no ecrã.



## Ligue a câmara ao computador

- 1 Ligue a câmara ao computador através do cabo USB (incluído).
  - O ecrã ligar-se-á automaticamente.

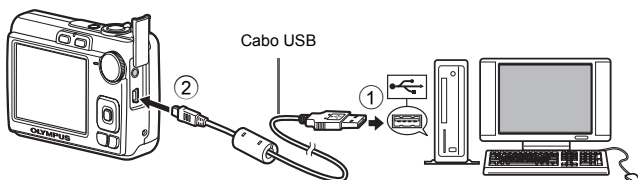

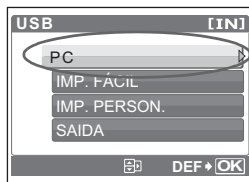

- 2 Seleccione [PC] no monitor e prima **OK**.



- O seu PC reconhecerá agora a sua câmara como uma unidade de armazenamento amovível.



## Transfira imagens para o computador

- 1 Com a câmara agora ligada, abra o OLYMPUS Master.
- 2 Fazer clique em “Transferir Imagens”  na janela de navegação e, depois, em “Da câmara” .
- 3 Basta seguir as instruções no ecrã.

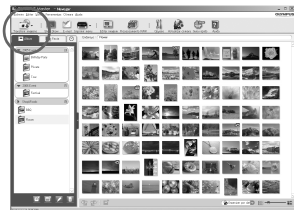

Pt

## Dicas

- Para obter informações pormenorizadas sobre a configuração e utilização da câmara, consulte o “Manual Avançado” da câmara fornecido em CD-ROM.
- Para obter assistência adicional, consulte o ficheiro “Ajuda” no software OLYMPUS Master.

# Software OLYMPUS Master

Software OLYMPUS Master: Utilize este software para transferir imagens da câmara, ver, organizar, retocar, enviar por correio electrónico e imprimir as suas imagens digitais, vídeos e mais!



## ● Requisitos do sistema

SO	Windows 2000 Professional/XP Home Edition/XP Professional/Vista ou Mac OS X (v10.3 ou superior)
CPU	Pentium III 500 MHz/Power PC G3 500 MHz/Intel Core Solo/Duo 1.5 GHz ou superior
RAM	256 MB ou superior
Capacidade do disco rígido	500 MB ou superior
Ligação	Porta USB/Porta IEEE 1394 (FireWire)
Ecrã	Resolução de 1024 × 768 pixels ou superior com no mínimo 65.536 cores (Windows), 32.000 cores (Macintosh)
Outro	Internet Explorer 6 ou superior (Windows) Safari 1.0 ou superior, QuickTime 6 ou superior (Macintosh)

Pt

Para obter as informações mais recentes de suporte técnico, visite o sítio da Web da Olympus  
(<http://www.olympus.com/digital>)



### Registo do utilizador

Quando instalar o OLYMPUS Master, registe a sua câmara para activar a garantia, receber avisos sobre actualizações de software e do firmware da câmara e muito mais.

# Especificações

## ● Câmara

Tipo de produto	: Câmara Digital (para fotografar e visualizar)
Sistema de gravação	
Fotografias	: Gravação Digital, JPEG (de acordo com o Norma de concepção para sistemas de ficheiros de câmara (DCF))
Normas aplicáveis	: Exif 2.2, Digital Print Order Format (DPOF), PRINT Image Matching III, PictBridge
Vídeo	: AVI Motion JPEG
Memória	: Memória interna xD-Picture Card (16 MB a 2 GB) (Type H/M, Standard)
Número de pixels efectivos	: 7.100.000 pixels
Dispositivo de captação de imagens	: 1/2,5" CCD (filtro de cor primária), 7.400.000 pixels (brutos)
Objectiva	: Objectiva Olympus de 6,3 a 18,9 mm, f3,1 a 5,9 (equivalente a 38 a 114 mm numa câmara 35 mm)
Sistema fotométrico	: Medição ponderada ao centro
Velocidade obturador	: 4 a 1/2000 seg.
Amplitude de fotografia	: 0,6 m a $\infty$ (W), 1,0 m a $\infty$ (T) (normal) 0,1 m a $\infty$ (W), 0,6 m a $\infty$ (T) (modo macro) 0,05 m a $\infty$ (modo super macro)
Ecrã	: Visor LCD a cores de 2,5" TFT, 154.000 pixels
Conector exterior	: Ficha DC-IN, conector USB, Entrada VIDEO OUT
Sistema de calendário automático	: 2000 até 2099
Ambiente de funcionamento	
Temperatura	: 0°C a 40°C (funcionamento)/ -20°C a 60°C (armazenamento)
Humidade	: 30% a 90% (funcionamento)/ 10% a 90% (armazenamento)
Alimentação	: 2 pilhas tamanho AA cada (pilhas Oxyride/pilhas alcalinas/pilhas NiMH) ou o adaptador de CA especificado
Dimensões	: 90 mm (L) × 62,5 mm (A) × 30,5 mm (P) (excluindo partes salientes)
Peso	: 122 g (sem pilha e placa)

Note que melhorias no design e nas especificações podem resultar em alterações sem aviso prévio.

# Precauções de segurança



## CUIDADO

NÃO ABRIR, PERIGO DE CHOQUE ELÉCTRICO



**CUIDADO:** PARA REDUZIR O RISCO DE CHOQUE ELÉCTRICO, NÃO RETIRE A TAMPÁ (OU COBERTURA POSTERIOR). NÃO TOQUE NAS PARTES INTERNAS. CONTACTE OS SERVIÇOS TÉCNICOS QUALIFICADOS DA OLYMPUS.



O ponto de exclamação dentro de um triângulo, alerta o utilizador sobre a presença de partes importantes para o funcionamento e manutenção (serviços técnicos). Ver as instruções que acompanham este produto.



### PERIGO

Se o produto for utilizado sem observância das informações acompanhadas deste símbolo, poderão ocorrer lesões graves ou morte.



### ADVERTÊNCIA

Se o produto for utilizado sem observância das informações acompanhadas deste símbolo, poderão ocorrer lesões ou morte.



### PRECAUÇÃO

Se o produto for utilizado sem observância das informações acompanhadas deste símbolo, poderão ocorrer lesões pessoais, danos no equipamento ou a perda de dados importantes.

#### ATENÇÃO!

PARA REDUZIR O RISCO DE FOGO OU DE CHOQUES ELÉCTRICOS, NÃO EXPONHA ESTE EQUIPAMENTO À CHUVA, EM CONTACTO COM LÍQUIDOS OU EM LOCAIS COM HUMIDADE.

Pt

## Precauções Gerais

**Leia todas as instruções** — Antes de utilizar o produto, leia todas as instruções de funcionamento. Guarde todos os manuais e instruções de segurança para futuras consultas.

**Limpeza** — Desligue sempre da tomada, antes de o limpar. Utilize apenas um pano macio para limpeza. Para limpar, nunca use nenhum tipo de líquido ou aerossol, ou solvente orgânico.

**Acessórios** — Para sua segurança e para evitar danos no produto, utilize apenas acessórios recomendados pela Olympus.

**Água e Humidade** — Para consultar as precauções sobre os produtos com características à prova de água, leia as respectivas secções.

**Localização** — Para evitar danos no produto, monte-o com segurança sobre um tripé, estante ou suporte estável.

**Fonte de energia** — Ligue este aparelho à fonte de energia designada para ele.

**Relâmpagos** — Se houver uma tempestade durante a utilização de um adaptador CA, desligue-o imediatamente da tomada da parede.

**Objectos estranhos** — Para evitar lesões pessoais, nunca insira objectos metálicos dentro do produto.

**Calor** — Nunca use ou guarde este produto perto de fontes de calor, tais como radiadores, aquecedores ou qualquer tipo de equipamento ou ferramenta que produza calor, incluindo amplificadores de som.

## Manuseamento da Câmara



### ADVERTÊNCIA

- **Não utilize a câmara perto de gases inflamáveis ou explosivos.**
- **Não utilize o flash a curta distância das pessoas (especialmente crianças, adolescentes, etc.).**
  - Deverá manter-se a uma distância mínima de 1 m da face das pessoas. Se disparar o flash muito próximo dos olhos da pessoa, pode causar uma perda momentânea da visão.
- **Mantenha as crianças e adolescentes fora do alcance da câmara.**
  - Utilize e guarde sempre a câmara fora do alcance das crianças e menores, para prevenir as seguintes situações de perigo que poderiam causar sérias lesões:
    - Ficar preso na correia da câmara, ocasionando asfixia.
    - Ingerir acidentalmente uma pilha ou uma pequena peça.
    - Disparar o flash acidentalmente sobre os seus próprios olhos ou sobre os olhos de uma criança.
    - Lesionar-se acidentalmente com as peças móveis da câmara.
- **Não olhe para o sol ou para luzes fortes através da câmara.**
- **Não utilize nem guarde a câmara em locais com pó ou humidade.**
- **Durante o disparo, não obstrua o flash com a mão.**

Pt



### PRECAUÇÃO

- **Interrompa imediatamente a utilização da câmara se notar algum cheiro, ruído ou fumo estranho a sair.**
  - Nunca remova as pilhas com as mãos desprotegidas, pois pode provocar fogo ou queimar as suas mãos.
- **Nunca opere nem guarde a câmara com as mãos molhadas.**
- **Não deixe a câmara em locais onde possa estar sujeita a elevadas temperaturas.**
  - Caso contrário, as peças da câmara podem deteriorar-se e, em algumas circunstâncias, provocar incêndio na câmara. Não usar o carregador ou o adaptador de CA se estiver coberto (por exemplo, com um cobertor). Caso contrário, pode provocar sobreaquecimento ou fogo.
- **Manuseie a câmara com cuidado de modo a evitar alguma queimadura provocada por baixo calor.**
  - Quando a câmara contém peças metálicas, pode ocorrer o sobreaquecimento das mesmas, resultando em queimaduras provocadas por baixo calor. Ter em atenção o seguinte:
    - Quando usada durante um longo período, a câmara ficará quente. Se continuar a segurar a câmara nestas condições, pode ocorrer uma queimadura de baixo calor.
    - Em locais sujeitos a temperaturas extremamente frias, a temperatura do corpo da câmara pode ser inferior à temperatura ambiente. Se possível, usar luvas ao manusear a câmara a baixas temperaturas.

● **Tenha cuidado com a correia.**

- Quando transportar a câmara tenha cuidado com a correia, já que, uma vez que é fácil enlaçá-la em objectos soltos em objectos soltos e causar sérios danos.

**Precauções a respeito da manipulação das pilhas**

**Siga estas importantes indicações para evitar que ocorram fugas de líquido, sobre-aquecimento, incêndio ou explosão das pilhas ou para evitar choques eléctricos ou queimaduras.**



**PERIGO**

- Utilize somente as pilhas NiMH e o carregador apropriado de marca Olympus.
- Nunca aqueça ou queime as pilhas.
- Tome precauções ao transportar ou guardar as pilhas a fim de evitar que entrem em contacto com objectos metálicos, tais como agramos, ganchos, jóias, etc.
- Nunca guarde as pilhas em lugares onde fiquem expostas à luz solar directa ou sujeitas a altas temperaturas ou no interior de um veículo com aquecimento, perto de uma fonte de calor, etc.
- Para evitar que ocorram fugas de líquido das pilhas ou danos dos seus terminais, siga cuidadosamente todas as instruções respeitantes ao uso das pilhas. Nunca tente desmanchar a pilha nem modificá-la de nenhuma maneira, por soldadura, etc.
- Se o líquido da pilha penetrar nos seus olhos, lave-os de imediato com água corrente fresca e limpa, procurando assistência médica logo em seguida.
- Guarde as pilhas sempre fora do alcance das crianças. Se um menor ingerir uma pilha acidentalmente, procure assistência médica imediatamente.



**ADVERTÊNCIA**

- Mantenha as pilhas sempre secas.
- Para evitar fugas de líquido, sobre-aquecimento, incêndio ou explosão, utilize exclusivamente as pilhas recomendadas para este produto.
- Nunca misture as pilhas (novas com usadas, carregadas com descarregadas, de diferentes marcas ou capacidade, etc.).
- Não recarregue pilhas alcalinas nem pilhas de lítio se as mesmas não forem recarregáveis.
- Insira a pilha cuidadosamente conforme descrito no manual de instruções.
- Não utilize pilhas que não estão revestidas com protecção isolante ou que estão com a protecção danificada, visto que poderá ocorrer vazamento de líquido, provocar incêndio ou lesões.

## PRECAUÇÃO

- Não remova as pilhas logo após desligar a câmara. As pilhas podem ficar quentes durante o uso prolongado.
- Remova a pilha da câmara sempre que for guardar a câmara por um período prolongado.

- As seguintes pilhas tipo AA não podem ser utilizadas.

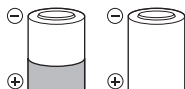

Pilhas parcialmente cobertas ou sem a cobertura da protecção isoladora.



Pilhas com os terminais  $\ominus$  em relevo, mas sem a protecção isoladora.

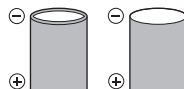

Pilhas com os terminais rasos, mas não completamente cobertos pela protecção isoladora. (Tais pilhas não podem ser utilizadas mesmo que os terminais  $\ominus$  estejam parcialmente cobertos.)

- Se as pilhas de NiMH não recarregarem dentro do tempo especificado, interrompa a recarga e não as utilize.
- Não usar uma pilha se estiver rachada ou partida.
- Se ocorrer um vazamento, descoloração ou deformação da pilha, ou qualquer outra anormalidade durante a operação, interrompa o uso da câmara.
- Se o líquido da pilha entrar em contacto com a roupa ou a pele, retire a roupa e lave de imediato a parte afectada com água corrente fresca e limpa. Se o líquido queimar a pele, solicite imediatamente cuidados médicos.
- Nunca exponha as pilhas a fortes impactos nem a vibrações contínuas.

## Para Clientes na América do Norte e do Sul

### Para Clientes nos EUA

Declaração de Conformidade

Modelo Número : FE-210/X-775

Nome Comercial : OLYMPUS

Parceiro Responsável: OLYMPUS IMAGING AMERICA INC.

Morada : 3500 Corporate Parkway, P.O. Box 610, Center Valley, PA  
18034-0610 EUA.

Telefone Número : 484-869-5000

Testada Em Conformidade Com O Standard FCC  
PARA USO DOMÉSTICO OU NO ESCRITÓRIO

Este aparelho está em conformidade com a Capítulo 15 das Regras FCC. O seu funcionamento está sujeito a duas condições:

- (1) Este aparelho não pode causar perigo de interferência.
- (2) Este aparelho pode receber qualquer tipo de interferência, inclusive interferências que possam originar o seu mau funcionamento.

### Para Clientes no Canadá

Este aparelho digital da Classe B está em conformidade com a Regulamentação Canadiana para Equipamentos Causadores de Interferências.

## Marcas Comerciais

- A IBM é uma marca comercial registada da International Business Machines Corporation.
- Microsoft e Windows são marcas comerciais registadas da Microsoft Corporation.
- Macintosh é uma marca comercial registada da Apple Computers Inc.
- xD-Picture Card™ é uma marca registada.
- Todas as outras companhias e nomes de produtos são marcas comerciais registadas e/ou marcas comerciais dos respectivos fabricantes.
- Os standards referidos neste manual para os sistemas de ficheiro da câmara são os standards DCF ("Design Rule for Camera File System") estipulados pela JEITA ("Japan Electronics and Information Technology Industries Association").



---

## Memo

---

## Memo

---

## Memo

# OLYMPUS®

<http://www.olympusamerica.com/>

## OLYMPUS IMAGING AMERICA INC.

3500 Corporate Parkway, P.O. Box 610, Center Valley, PA 18034-0610, U.S.A. Tel. 484-896-5000

### Technical Support (USA)

24/7 online automated help: <http://www.olympusamerica.com/support>

Phone customer support: Tel. 1-888-553-4448 (Toll-free)

Our phone customer support is available from 8 am to 10 pm (Monday to Friday) ET

E-Mail: [distec@olympus.com](mailto:distec@olympus.com)

Olympus software updates can be obtained at: <http://www.olympusamerica.com/digital>

To find the nearest Service Centers, please visit: <http://www.olympusamerica.com/digital>, and click on the Worldwide Warranty icon at the bottom of the page.

### Service Centers

#### U.S.A.:

##### California Olympus Imaging America Inc.

10805 Holder Street Suite 170  
Cypress, CA 90630-5145  
Tel: (888) 553-4448

##### New York Olympus Imaging America Inc.

400 Rabro Drive  
Hauppauge, NY 11788-4258  
Tel: (888) 553-4448

#### Canada:

##### Mississauga Olympus Canada Inc.

**Consumer Products Group**  
151 Telson Road  
Markham, Ontario Canada L3R 1E7  
Tel. 1-866-267-3039

#### Mexico:

##### Olympus Imaging de Mexico S.A. de C.V.

WTC Mexico,  
Montecito No.38 - Lobby - Office 3  
Col. Napoles, Mexico D.F. 03810  
Tel. (01800)800-2128  
E-mail: [pedro.jimenez@olympus.com](mailto:pedro.jimenez@olympus.com)

#### Argentina:

##### Jesus Labrador S.A.

Paraguay 755 PB, C1057 AAI Buenos Aires  
Tel: (011) 4313-3174 Fax: (011) 4312-5239  
E-Mail: [jesuslabrador@speedy.com.ar](mailto:jesuslabrador@speedy.com.ar)

##### Jesus Labrador S.A.

Sucursal Mitre, Bartolome Mitre 860  
C1036AAP Buenos Aires Tel: (011) 4331-1227  
E-mail: [jesuslabrador@speedy.com.ar](mailto:jesuslabrador@speedy.com.ar)

#### Brazil:

##### Rio de Janeiro Assistec

Rua Uruguaiana, 94-Sobrelaja  
Centro-Rio de Janeiro CEP 20050-091  
Tel: (021) 2242-3236 Fax: (021) 2242-3236  
E-Mail: [rio@assistecs.com.br](mailto:rio@assistecs.com.br)

##### Sao Paulo Assistec

Rua Avanhandava 126, 3 Andar  
Consolação, São Paulo  
Tel: (011) 3123-3100 Fax: (011) 3214-0706  
E-mail: [ASSISTECSS@UOL.COM.BR](mailto:ASSISTECSS@UOL.COM.BR)

##### Assistec

Filial Shopping Eldorado  
Av. Rebouças 3970, 1 Subsolo, Loja 1035  
Pinheiros, Sao Paulo  
Tel: (011) 3815-3054 Fax: (011) 3814-4398  
E-mail: [ASSISTECSS@UOL.COM.BR](mailto:ASSISTECSS@UOL.COM.BR)

#### Chile:

##### REIFSCHEIDER S.A.

Camino El Conquistador del Monte 5024  
Huechuraba, Santiago  
Tel: 56-2-6781200  
Fax: 56-2-6781202  
E-mail: [olympus@reifschneider.cl](mailto:olympus@reifschneider.cl),  
[serviciotecnico@reifschneider.cl](mailto:serviciotecnico@reifschneider.cl)

#### Colombia:

##### CV Tronica Ltda

Calle 68 No 12-57, Bogota  
Tel: (0571)235-7260/348-1573  
Fax: (0571) 348-1574  
E-mail: [servicio@cvtronica.com](mailto:servicio@cvtronica.com)

#### Panama:

##### FOTOSER

Edif. El Paical, Oficina No3, P.A.  
Urb. Herbruger, Transistmica  
(Detras del S/M Riba Smith),  
Tel/Fax: (507) 261-0436  
E-mail: [rearanda@rocketmail.com](mailto:rearanda@rocketmail.com)

#### Uruguay:

##### Fotocamara S.R.L.

Rondeau 1470 Montevideo  
Tel: (02) 900-2004 Fax: (02) 900-8430  
E-mail: [FOTOCAM@ADINET.COM.UY](mailto:FOTOCAM@ADINET.COM.UY)

#### Venezuela:

##### Micron C.A.

4ta. transversal Urb. Horizonte,  
Edificio América, Mezanine, Caracas 1070-A  
Tel: (0212) 238-3526 Fax: (0212) 239-8598  
E-mail: [guillemolandaeta@micron.com.ve](mailto:guillemolandaeta@micron.com.ve)